

REQ. PER UNIT	MODEL	USED ON	DATE
		ABSY. NO.	
		AD-102	E

# STANDARD DRAWING

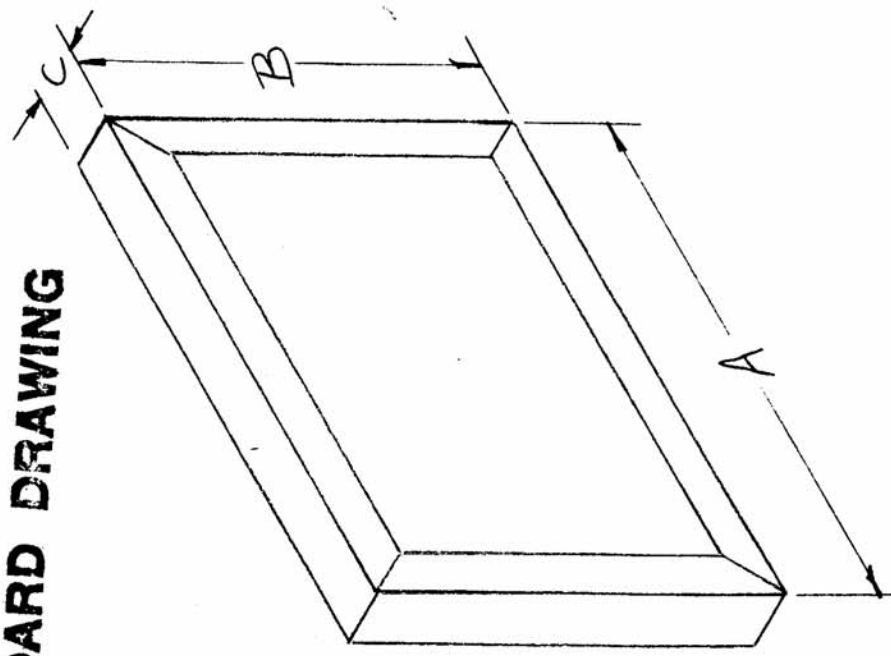

T.M.C. PART NO	R.P. PART NO	A (INCHES)	B (INCHES)	C (INCHES)	TRIM TO SIZE PADS
AD-102-1		4	4	1/2	DOUBLE
AD-102-2		5 1/2	5 1/2	1	DOUBLE
AD-102-3		16	11 3/4	1	DOUBLE
AD-102-4		4	4	1/2	SINGLE
AD-102-5		3 5/8	6 5/8	1/2	SINGLE
AD-102-6		10 1/8	11 3/8	1/2	SINGLE
AD-102-7		7 5/8	16 7/8	1/2	SINGLE
AD-102-8		6 5/8	6 5/8	1/2	SINGLE
AD-102-9		16	16	1/2	SINGLE

UNLESS OTHERWISE SPECIFIED ALL DIMENSIONS ARE FOR REF.

REF: RESEARCH PRODUCTS CORP.

REQ. ITEM	PART NO.	DESCRIPTION	SYMBOL
		THE TECHNICAL MATERIEL CORP. MAMARONECK, NEW YORK	
		ALUMALLOY	
		STOCK SIZE	
		MATERIAL	
		TYPE & TEMPER	
		HEAT TREAT. SPEC.	
		FINISH & SPEC. NO.	

DATE	CH. NO.	DRAFTS	CHECKER	ENG. APP.
7.11.66	16526	WHD	gfb	
1/8/59	4	16	Whe	gfb
10/9/58	3	Whe	gfb	gfb
4/18/58	2	16	WHD	gfb
3/13/58	1	WHD	WHD	gfb

DEC. DIM. ±	SCALE:
FRAC. DIM. ±	MAXIMUM ALLOWABLE TOLERANCES HAVE BEEN DETERMINED AND ANY DEVIATIONS WILL BE CAUSE FOR REJECTION.
ANGULAR DIM. ±	REMOVE ALL BURRS AND SHARP EDGES

TYPE & TEMPER	HEAT TREAT. SPEC.	CHECKED	FINAL APPROVAL
		WHD 3/8/58	A.J.J.
FINISH & SPEC. NO.	ELEC. DES. APP.	MECH. DES. APP.	
			AD-102
			E