

IF IT IS FOUND DESIRABLE TO CHANGE ANY TOLERANCE OR OTHER DETAIL SPECIFIED ON THIS DRAWING NOTIFY THE PURCHASER PROMPTLY.

MAXIMUM ALLOWABLE TOLERANCES HAVE BEEN DETERMINED AND DEVIATIONS WILL BE CAUSE FOR REJECTION. REMOVE ALL BURRS AND SHARP EDGES

FINISH NOTE  
 S-114 - ZINC CHROMATE PRIMER  
 S-115 - SMOOTH GRAY ENAMEL

A-948 A

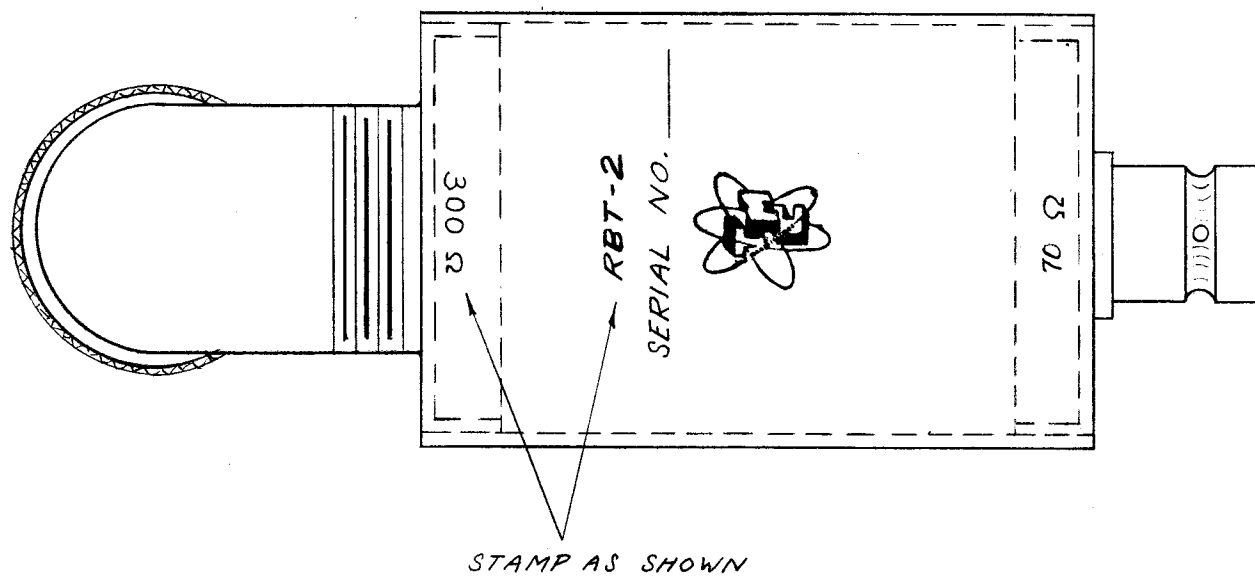
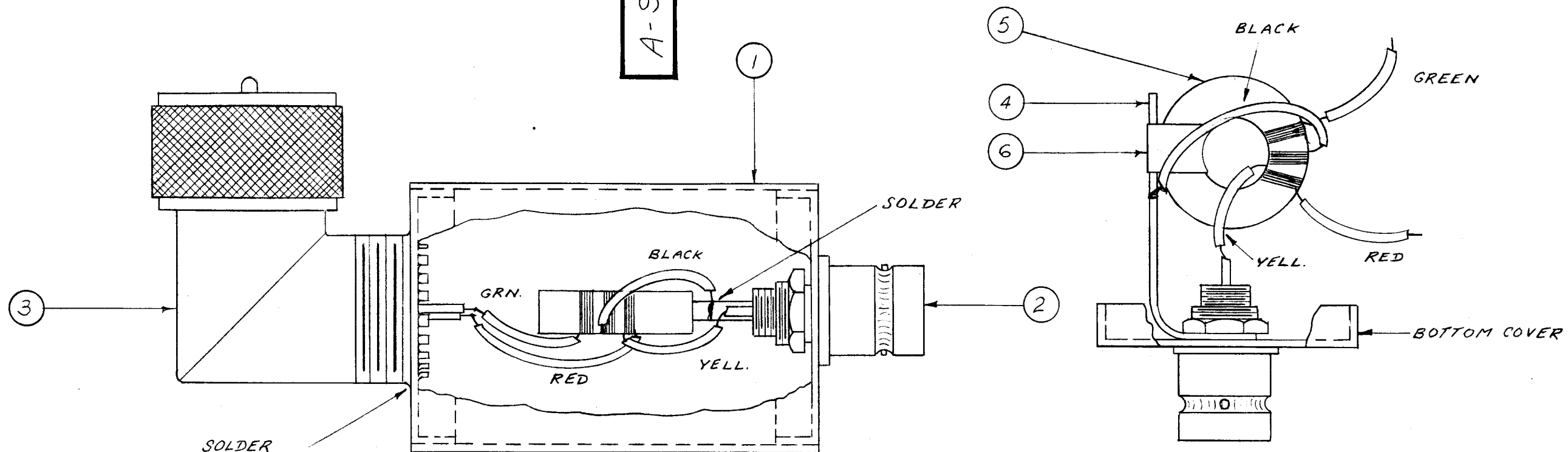

X	8	BS-100	SOLDER, SOFT	
X	7	GL-106	POTTING COMPOUND (PLASTIC)	
X	6	TA-105-1	TAPE, MASKING	
1	5	A-1082	TRANSFORMER (WINDING DATA)	
7	4	TE-III-2	LUG, SOLDER	
1	3	UG-104/U	ADAPTOR	
1	2	UG-625/U	RECEPTACLE	
1	1	BX-132	CASE TRANSFORMER	

REQ. ITEM	PART NO.	DESCRIPTION	SYMBOL
<b>THE TECHNICAL MATERIEL CORP.</b>			
<b>MAMARONECK. NEW YORK</b>			
<b>RBT-2 ASSEMBLY</b>			
STOCK SIZE			
MATERIAL		WEIGHT PER PC.	
TYPE & TEMPER		10-3-4-55	23
HEAT TREAT. SPEC.		MECH. DES. APP.	WJ
SEE NOTE		CHECKED	FINAL APPROVAL
FINISH & SPEC. NO.		A-948 A	

A	1	RBT STAMP WAS RTB	1/7/57	1	16	JMS	AK
ISSUE	ITEM	CHANGED FROM	DATE	CN. NO.	DRAFTS	CHECKER	ENG. APP.
TOLERANCES			SCALE:				
ALL OTHERS	DEC. DIM. ±	DRILL, PUNCH, COMMERCIAL STOCK SIZES AND MANUFACTURERS TOLERANCES ARE NOT INCLUDED.					
	FRAC. DIM. ±						
	ANGULAR DIM. ±						

1	RBT-2		3-4-55
REQ. PER UNIT	MODEL	PROJECT NO.	DATE
USED ON			