

IF IT IS FOUND DESIRABLE TO CHANGE ANY TOLERANCE OR OTHER DETAIL SPECIFIED IN THIS DRAWING NOTIFY THE PURCHASER PROMPTLY.

MAXIMUM ALLOWABLE TOLERANCES HAVE BEEN DETERMINED AND DEVIATIONS WILL BE CAUSE FOR REJECTION. REMOVE ALL BURRS AND SHARP EDGES

DRILL & TAP 6-32 NC-2
2 REQ'D

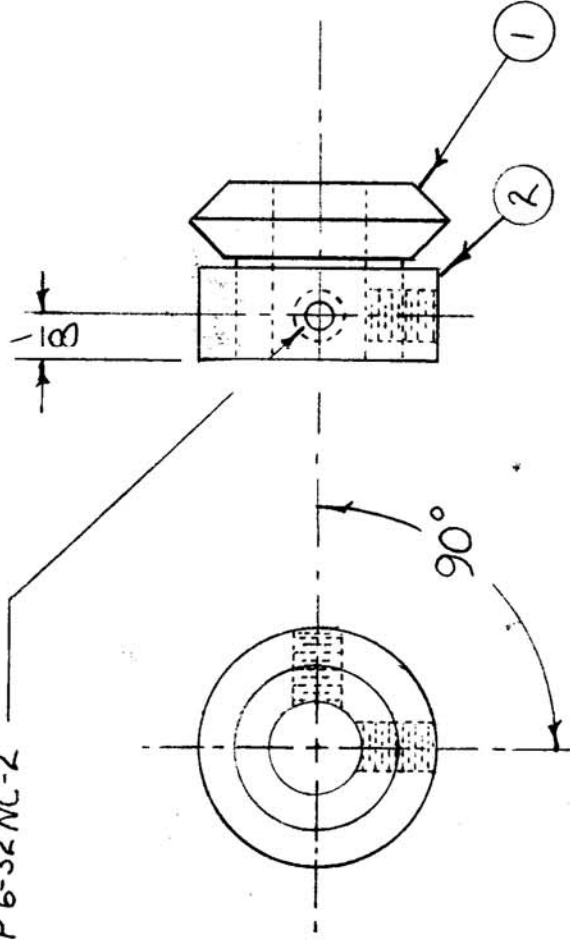

.2510
.2505

A-939

B

REQ. PER UNIT	MODEL	PROJECT NO.	ASSY. NO.	DATE
2	VOX-1			3-3-55
2	VOX-2			3-3-55
2	RTF			2/2/56
2	RTF-1			4/17/56
2	RTF-2			4/17/56
2	RTF-2	M/D		11/20/58

USED ON

REQ. ITEM	PART NO.	DESCRIPTION	SYMBOL
1	2	COLLAR, MITER GEAR	
1	1	GEAR, MITER	

THE TECHNICAL MATERIEL CORP.
MAMARONECK, NEW YORK

MITER GEAR ASSEMBLY

STOCK SIZE	
MATERIAL	
WEIGHT PER PC.	
TYPE & TEMPER	
HEAT TREAT. SPEC.	
FINISH & SPEC. NO.	

B	1	SUPPLIER NOTE DELETED	64639125	9/27	WJL
A	1	GEAR LENGTH REDUCED	4.1116	10/20	JWL

CHANGED FROM

DATE CN. NO. DRAFTS CHECKER ENG. APP.

SCALE

TOLERANCES

DEC. DIM. ±
FRAC. DIM. ±
ANGULAR DIM. ±

DRILL, PUNCH, COMMERCIAL STOCK SIZES AND MANUFACTURERS TOLERANCES ARE NOT INCLUDED.

DRAWN		ELEC. DES. APP.		MECH. DES. APP.	
CHECKED					
FINAL APPROVAL					

A-939

B