

A-894 K

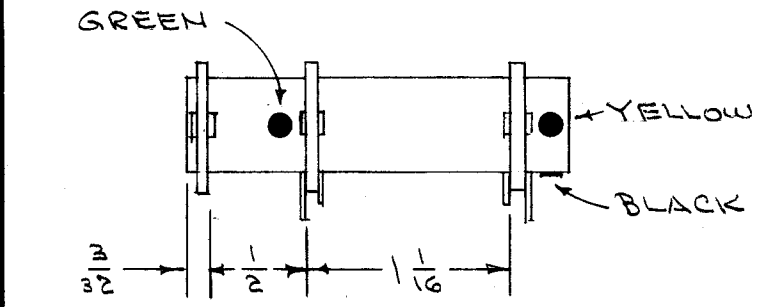

**COIL FORM ASSEMBLY**

- 1- CEMENT TERMINAL RINGS TO COIL FORM WITH ITEM 3 IN POSITION SHOWN ABOVE.
- 2- COLOR CODE COIL FORM AS ABOVE.

**WINDING MACHINE DATA**

RACK GEAR	100
RACK DRIVER GEAR	40
CAM	.125
CAM GEAR	49
DRIVER GEAR	95

**WINDING DATA**

- 1- STARTING AT GREEN LUG WIND ON 75 TURNS OF ITEM 2.
- 2- BRING OUT TWISTED TAP 1" LONG AS SHOWN.
- 3- CONTINUE WINDING FOR 27 1/4 TURNS MAKING A TOTAL OF 102 1/4 TURNS.
- 4- STAKE ENDS & TAP TO COIL FORM WITH ITEM 3.
- 5- STRIP, TIN & SOLDER LEADS TO LUGS AS SHOWN.
- 6- BAKE FOR 1/2 HOUR AT 215° F.
- 7- SATURATE COIL WITH ITEM 5, AND BAKE FOR 30 MIN. AT 215° F.
- 8- SOLDER 1" OF #22 BUSS BAR TO EACH LUG FOR TEST.
- 9- MAKE TESTS (SEE CHART). REMOVE TEST LEADS
- 10- SOLDER CAPACITOR IN PLACE AS SHOWN.
- 11- MEASURE DC RESISTANCE. (USE SIMPSON #260 OHMMETER OR EQUIVALENT).

**TEST DATA W/O CORE**

WINDING	L μh *	Q *	F	R Ω APP.
L1	115 (106-116)	95 OR GREATER	2.5 MC	7.0
L2	71 (67-75)	85 " "	"	5.2

\* BACHTON Q METER 160A OR EQUIVALENT

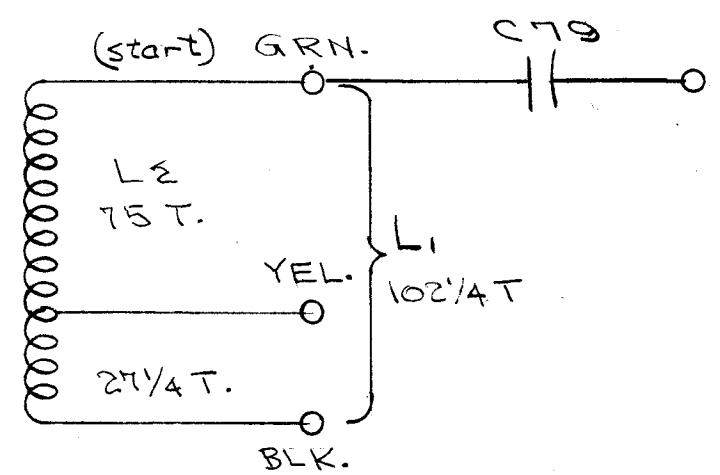

FREQ. RANGE .990 TO 1.905 M.C.

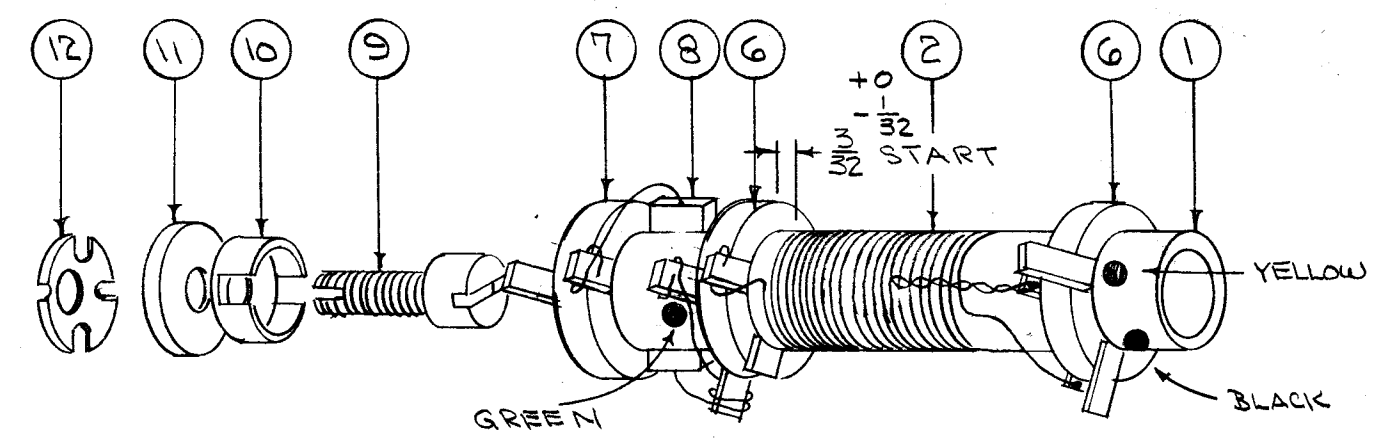

NOTE: KEEP CAPACITOR LEADS SHORT BUT DO NOT ALLOW CAPACITOR TO TOUCH A LUG.

COIL MUST BE INSTALLED IN CHASSIS BEFORE ITEMS 9-10-11-12 ARE CEMENTED TO COIL FORM WITH ITEM 13.

FOR IDENTIFICATION STAMP THE NUMBER 13 ON COIL FORM IN ANY CONVENIENT SPOT.

QTY	ITEM	PART NO.	DESCRIPTION	SYMBOL
X 13	GL-111		CEMENT, "INSA-LUTE"	
1	12	FS-112	FASTENER	
1	11	WA-125-2	WASHER, FIBER	
1	10	NT-112	NUT, SPEED	
1	9	CI-69-11	CORE	
1	8	CM25F431G03	CAPACITOR, FIXED	C79
1	7	TE-146-1	RING, TERMINAL	
2	6	TE-146-2A	" , "	
X 5	5	GL-102	Q MAX	
X 4	4	BS-100	SOLDER, SOFT	
X 3	3	GL-103	CEMENT, DUCO	
X 2	2	WI-104-341 SSE	WIRE, LITZ	
1	1	CF-112	COIL FORM	

REQ.	ITEM	PART NO.	DESCRIPTION	SYMBOL
<b>THE TECHNICAL MATERIEL CORP.</b> MAMARONECK, NEW YORK				
COIL, RF, TUNED, OSCILLATOR, BAND 1				
MATERIAL			CDD 7/24/76	
TYPE & TEMPER			HEAT TREAT. SPEC.	DRAWN
FINISH & SPEC. NO.			ELEC. DES. APP.	MECH. DES. APP.

ISSUE	ITEM	CHANGED FROM	DATE	CH. NO.	DRAFTS	CHECKER	ENG. APP.
K		ITB WAS CM20D431F	9/26/66	16892	RME	JCB	

REQ. PER UNIT	MODEL	PROJECT NO.	SYMBOL NO.	DATE
1	GPR-90	297	L13	5-23-60
				7-25-56

DEC. DIM. ±  
FRAC. DIM. ±  
ANGULAR DIM. ±

SCALE:  
MAXIMUM ALLOWABLE TOLERANCES HAVE BEEN DETERMINED AND ANY DEVIATIONS WILL BE CAUSE FOR REJECTION.  
REMOVE ALL BURRS AND SHARP EDGES

A-894 K