

IF IT IS FOUND DESIRABLE TO CHANGE ANY TOLERANCE OR OTHER DETAIL SPECIFIED ON THIS DRAWING NOTIFY THE PURCHASER PROMPTLY.

MAXIMUM ALLOWABLE TOLERANCES HAVE BEEN DETERMINED AND DEVIATIONS WILL BE CAUSE FOR REJECTION. REMOVE ALL BURRS AND SHARP EDGES

A-882

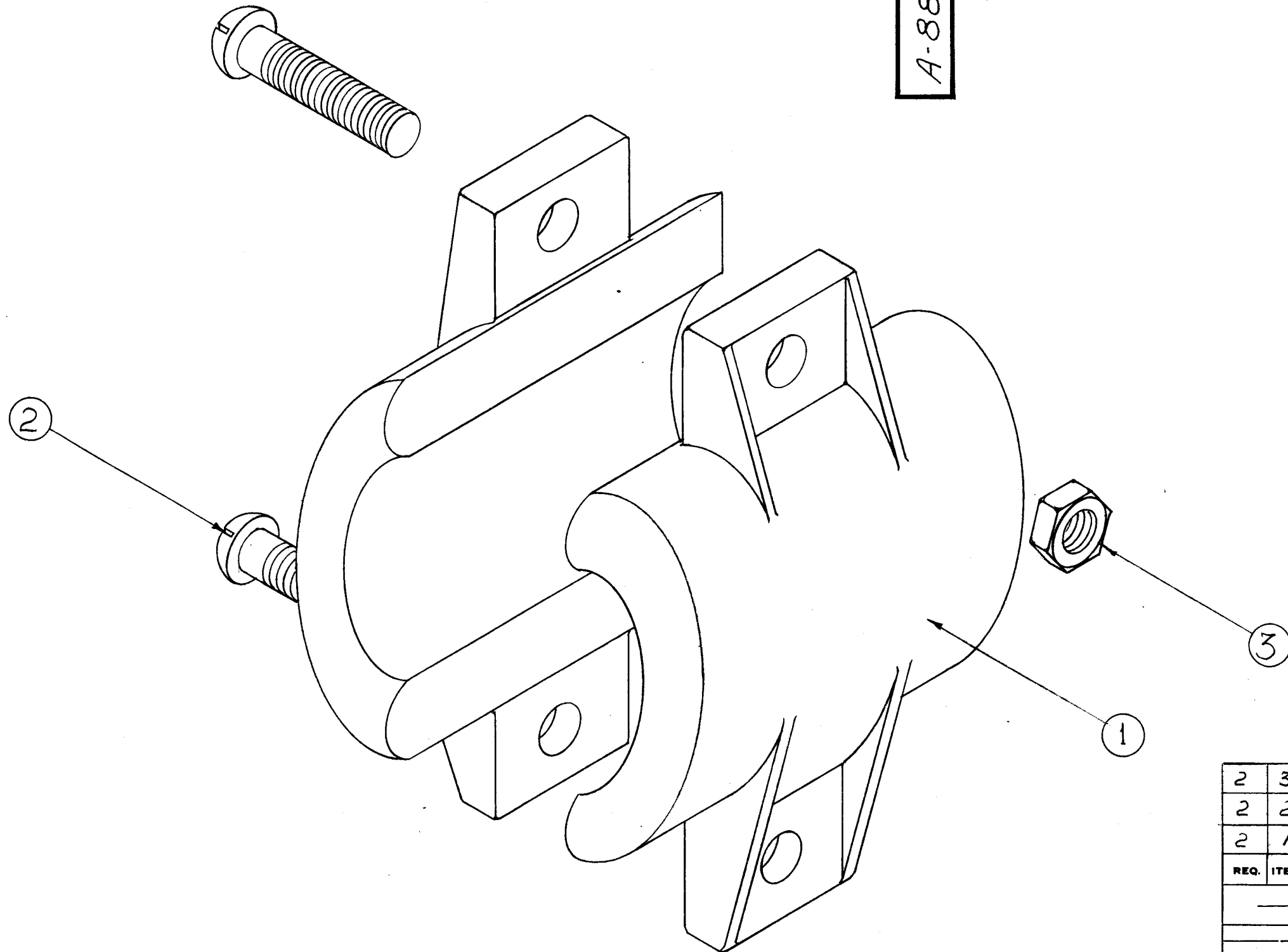

2	3	NTH3716SC20	NUT, HEX	
2	2	SCBS3716SC24	SCREW, MACHINE	
2	1	CS-117	CLAMP, FORMING	
REQ. ITEM	PART NO.		DESCRIPTION	SYMBOL
— # —			THE TECHNICAL MATERIEL CORP. MAMARONECK. NEW YORK	
STOCK SIZE				
— # —		— # —	CLAMP, FORMING	
MATERIAL		WEIGHT PER PC.	ASSY.	
— # —			P.B. 11-10-54	M.H.S.
TYPE & TEMPER			DRAWN	ELEC. DES. APP.
— # —			<i>[Signature]</i>	<i>[Signature]</i>
HEAT TREAT. SPEC.			CHECKED	FINAL APPROVAL
— # —			A-882	
FINISH & SPEC. NO.				

ISSUE	ITEM	CHANGED FROM	DATE	CN. NO.	DRAFTS	CHECKER	ENG. APP.
TOLERANCES			SCALE:				
ALL OTHERS	DEC. DIM. ±	FRAC. DIM. ±	DRILL, PUNCH, COMMERCIAL STOCK SIZES AND MANUFACTURERS TOLERANCES ARE NOT INCLUDED.				
	ANGULAR DIM. ±						

2	J-227	11-10-1954
REQ. PER UNIT	MODEL	PROJECT NO.
USED ON		