

IF IT IS FOUND DESIRABLE TO CHANGE ANY TOLERANCE OR OTHER DETAIL SPECIFIED ON THIS DRAWING NOTIFY THE PURCHASER PROMPTLY.

MAXIMUM ALLOWABLE TOLERANCES HAVE BEEN DETERMINED AND DEVIATIONS WILL BE CAUSE FOR REJECTION. REMOVE ALL BURRS AND SHARP EDGES

A-753 D.

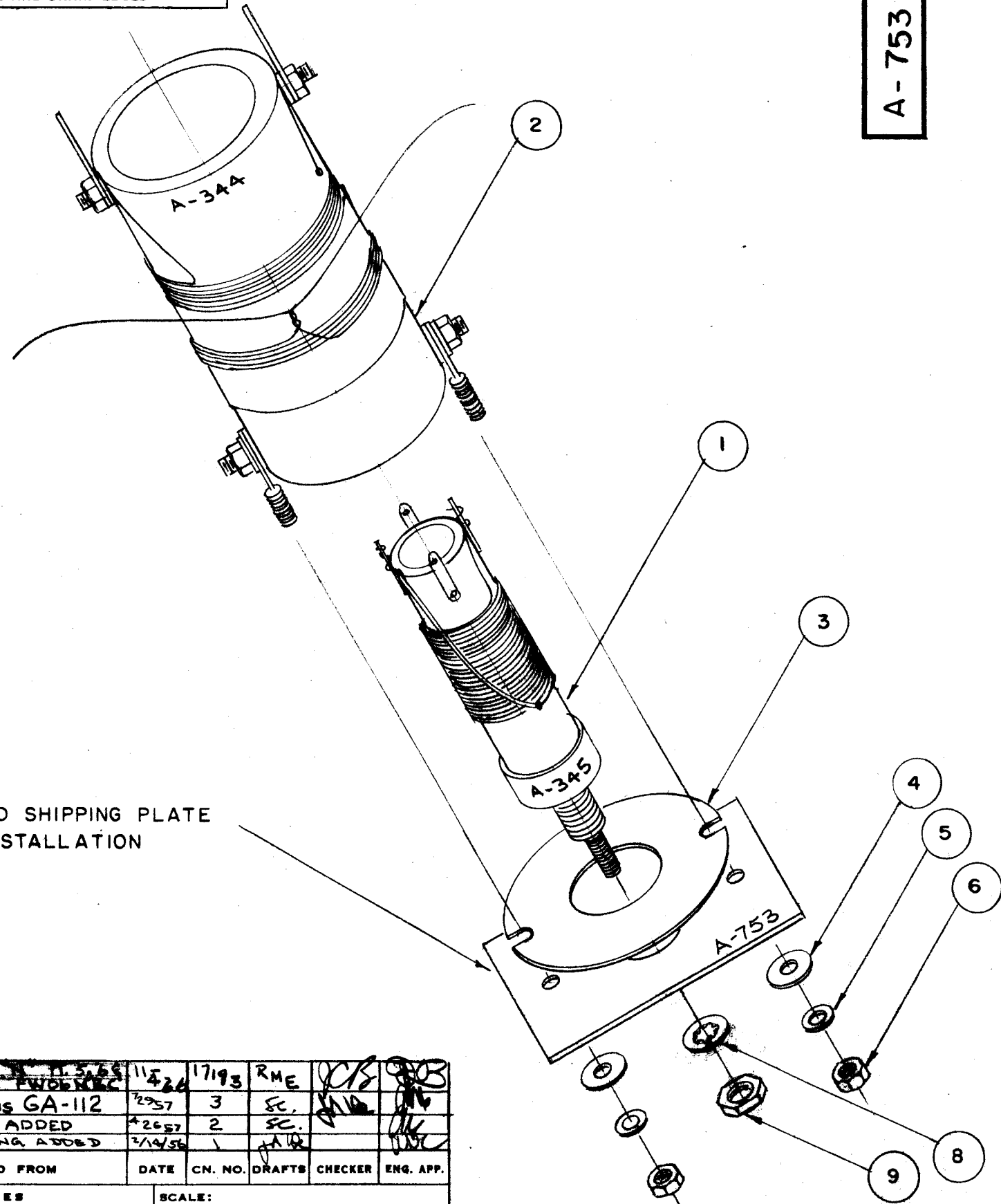

DISCARD SHIPPING PLATE ON INSTALLATION

REQ.	ITEM	PART NO.	DESCRIPTION	SYMBOL
1	9	NT-102	NUT, HEXAGON	
1	8	LWE25MRN	LOCK WASHER, EXTERNAL	
1	7	MS-527	SHIPPING PLATE	
2	6	NTH0632BN8	NUT, HEXAGON	
2	5	LWS06MRN	LOCK WASHER, SPLIT	
2	4	FW06M BN	WASHER, FLAT	
1	3	GA-133	INSULATION, COIL FORM	
1	2	A-344	MAIN SECTION T6	
1	1	A-345	TUNING SECTION T6	
			THE TECHNICAL MATERIEL CORP. MAMARONECK. NEW YORK	
STOCK SIZE			TRANSFORMER ASS'Y	
MATERIAL			T 6	
WEIGHT PER PC.				
TYPE & TEMPER			<i>JAD</i> 6-2-54 DRAWN ELEC. DES. APP.	
HEAT TREAT. SPEC.			CHECKED FINAL APPROVAL	
FINISH & SPEC. NO.			A-753	

ISSUE	ITEM	CHANGED FROM	DATE	CN. NO.	DRAFTS	CHECKER	ENG. APP.
D		CHG'D TO 11.545	11/5/54	115	17193	RME	<i>JAD</i>
C	1	GA-123 Was GA-112	2/25/54	3	SE.	<i>JAD</i>	<i>JAD</i>
B	1	ITEMS 8 & 9 ADDED	2/26/54	2	SE.	<i>JAD</i>	<i>JAD</i>
A	1	PLATE STAMPING ADDED	2/19/54	1	JAD		

TOLERANCES		SCALE:	
ALL OTHERS	DEC. DIM. ± FRAC. DIM. ± ANGULAR DIM. ±	DRILL, PUNCH, COMMERCIAL STOCK SIZES AND MANUFACTURERS TOLERANCES ARE NOT INCLUDED.	1 XFK
		MODEL PROJECT NO. ASSY. NO. DATE USED ON	

1	XFK	A-684	6-2-54
MODEL	PROJECT NO.	ASSY. NO.	DATE

IF IT IS FOUND DESIRABLE TO CHANGE ANY TOLERANCE OR OTHER DETAIL SPECIFIED ON THIS DRAWING NOTIFY THE PURCHASER PROMPTLY.

MAXIMUM ALLOWABLE TOLERANCES HAVE BEEN DETERMINED AND DEVIATIONS WILL BE CAUSE FOR REJECTION. REMOVE ALL BURRS AND SHARP EDGES

A-753 D

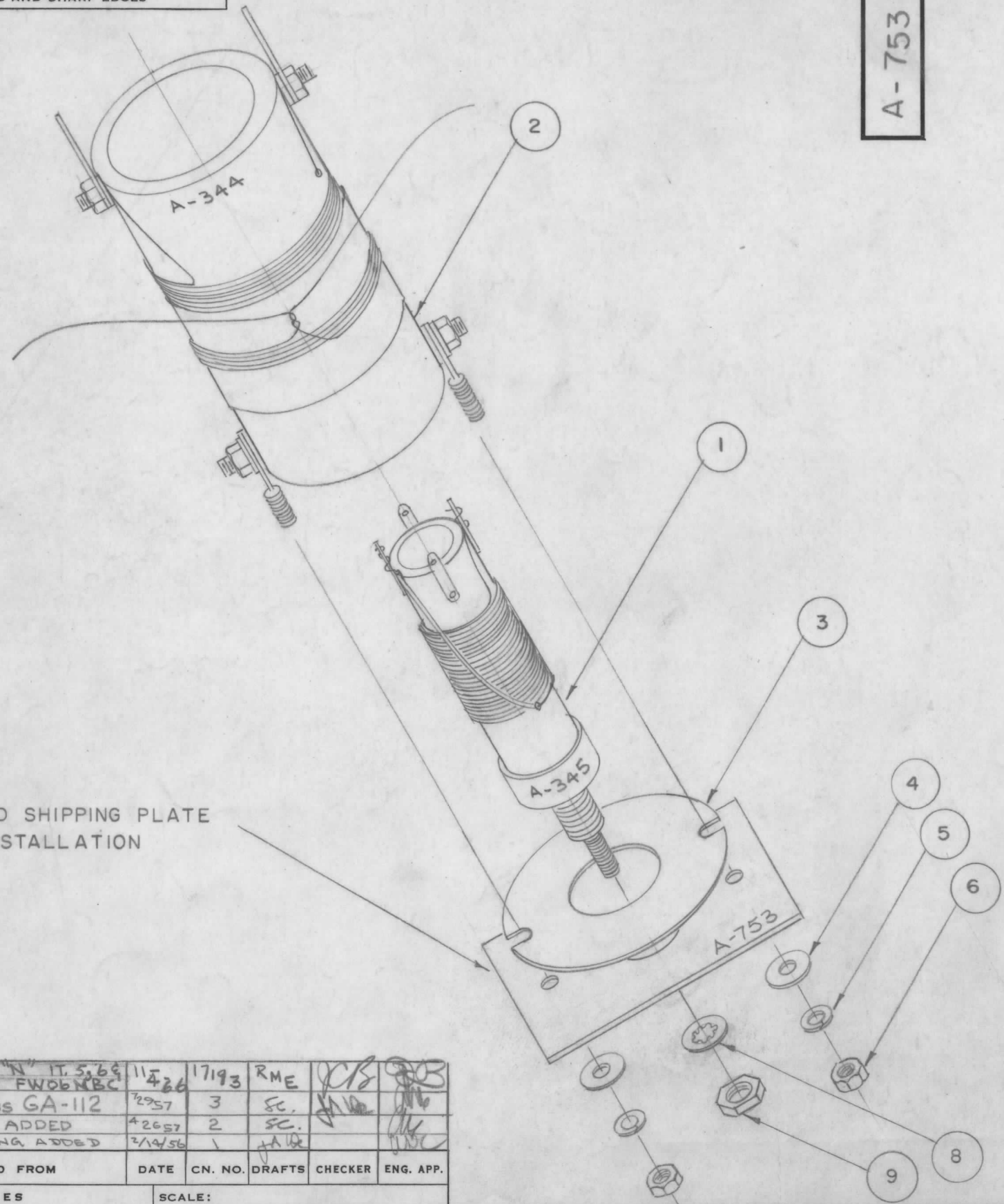

DISCARD SHIPPING PLATE ON INSTALLATION

REQ.	ITEM	PART NO.	DESCRIPTION	SYMBOL
1	9	NT-102	NUT, HEXAGON	
1	8	LWE25MRN	LOCK WASHER, EXTERNAL	
1	7	MS-527	SHIPPING PLATE	
2	6	NTH0632BN8	NUT, HEXAGON	
2	5	LWS06MRN	LOCK WASHER, SPLIT	
2	4	FW06H BN	WASHER, FLAT	
1	3	GA-133	INSULATION, COIL FORM	
1	2	A-344	MAIN SECTION T6	
1	1	A-345	TUNING SECTION T6	

STOCK SIZE		THE TECHNICAL MATERIEL CORP.	
		MAMARONECK. NEW YORK	
MATERIAL		TRANSFORMER ASS'Y	
WEIGHT PER PC.		T6	
TYPE & TEMPER		<i>JAD</i> 6-2-54 DRAWN ELEC. DES. APP. <i>WDE</i> MECH. DES. APP. <i>WDE</i>	
HEAT TREAT. SPEC.		CHECKED	
FINISH & SPEC. NO.		FINAL APPROVAL	

ISSUE	ITEM	CHANGED FROM	DATE	CN. NO.	DRAFTS	CHECKER	ENG. APP.
D		CHG'D "C" TO "N" IT. 5, 6 & B. IT 4 WAS FWO6HBN8	11/4/56	17193	RME	<i>JCB</i>	<i>WDE</i>
C	1	GA-133 Was GA-112	7/29/57	3	SC.	<i>JAD</i>	<i>WDE</i>
B	1	ITEMS 8 & 9 ADDED	4/26/57	2	SC.	<i>JAD</i>	<i>WDE</i>
A	1	PLATE STAMPING ADDED	2/14/56	1	JAD		

TOLERANCES		SCALE:	
ALL OTHERS	DEC. DIM. ± FRAC. DIM. ± ANGULAR DIM. ±	DRILL, PUNCH, COMMERCIAL STOCK SIZES AND MANUFACTURERS TOLERANCES ARE NOT INCLUDED.	

1	XFK	A-684	6-2-54
MODEL	PROJECT NO.	ASS'Y. NO.	DATE
USED ON			