

IF IT IS FOUND DESIRABLE TO CHANGE ANY TOLERANCE OR OTHER DETAIL SPECIFIED ON THIS DRAWING NOTIFY THE PURCHASER PROMPTLY.

MAXIMUM ALLOWABLE TOLERANCES HAVE BEEN DETERMINED AND DEVIATIONS WILL BE CAUSE FOR REJECTION. REMOVE ALL BURRS AND SHARP EDGES

A-752 B

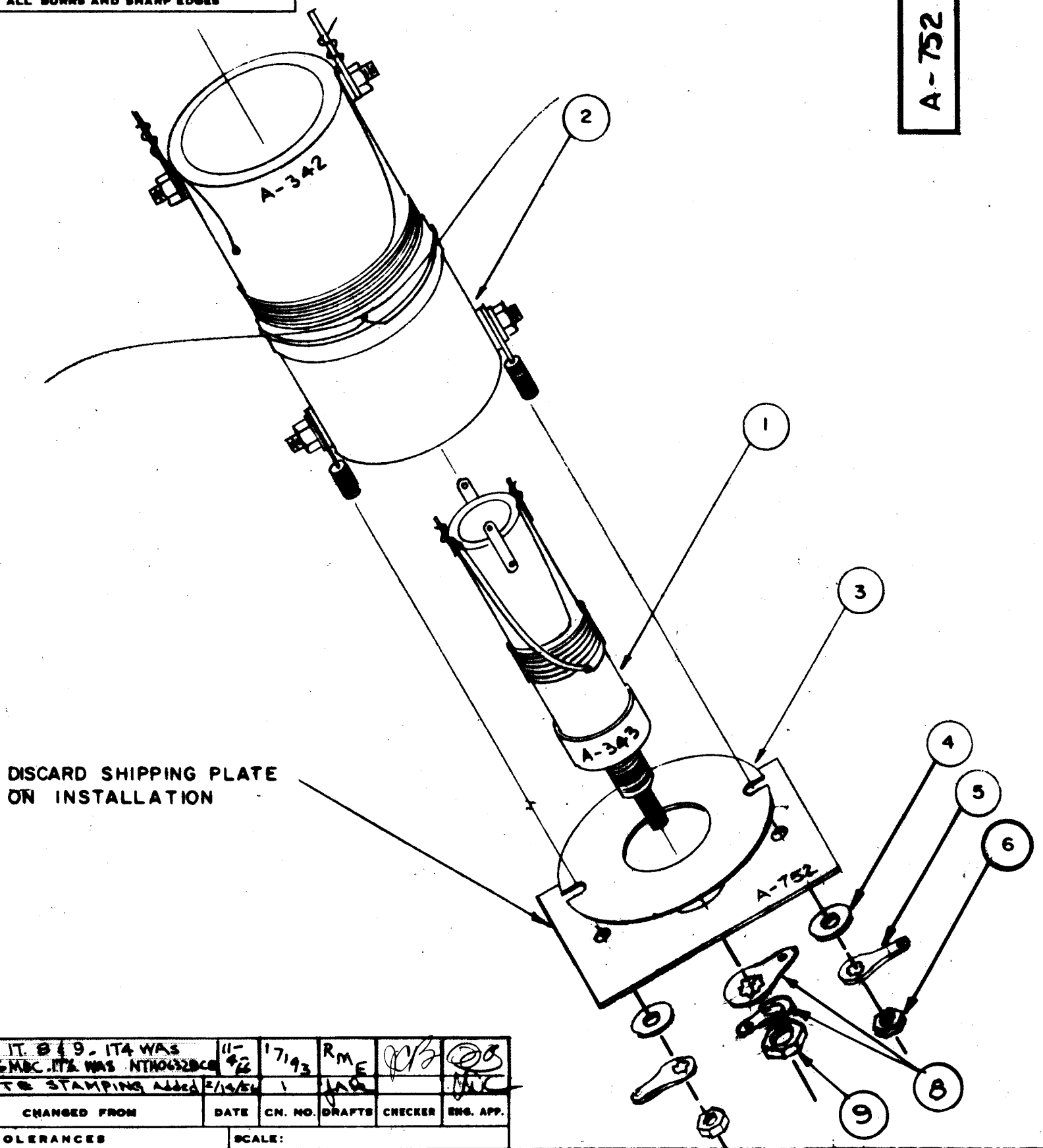

DISCARD SHIPPING PLATE ON INSTALLATION

1	9	NT102	NUT, HEXAGON	
2	8	TE104-5	LUG, SOLDER	
1	7	MS-527	SHIPPING PLATE	
2	6	NTH0632BN8	NUT, HEXAGON	
2	5	TE-104-2	LUG, SOLDER	
2	4	FW06H8N	WASHER, FLAT	
1	3	GA-112	INSULATION, COIL FORM	
1	2	A-342	MAIN SECTION T5	
1	1	A-343	TUNING SECTION T5	
REQ.	ITEM	PART NO.	DESCRIPTION	SYMBOL
			THE TECHNICAL MATERIEL CORP. MAMARONECK, NEW YORK	
STOCK SIZE			TRANSFORMER ASS'Y	
MATERIAL			T5	
WEIGHT PER PC.				
TYPE & TEMPER			C-2-54	
HEAT TREAT. SPEC.			E.S.S.	
			DRAWN	
			ELEC. DES. APP.	
			MECH. DES. APP.	
			CHECKED	
			FINAL APPROVAL	
			A-752 B	

B	ADD IT. B 49 - IT4 WAS FWO6H8N. IT2 WAS NTH0632BN8	11-42	17193	RME	WCB	WCB	
A	PLATE STAMPING Added	1/15/54	1	JAG		JAG	
ISSUE	ITEM	CHANGED FROM	DATE	CN. NO.	DRAFTS	CHECKER	ENG. APP.
TOLERANCES			SCALE:				
ALL OTHERS			DRILL PUNCH, COMMERCIAL STOCK SIZES AND MANUFACTURERS TOLERANCES ARE NOT INCLUDED.				

1	XFA	A-604	6-2-54
MODEL	PROJECT NO.	ASSY. NO.	DATE
USED ON			