

REVISIONS						
ZONE	LTR	DESCRIPTION	DATE	E.M.N.NO	DRAFT	CHKD APPD
	X1	COMPLETELY REVISED	12-10-84			
	X2	ADD CR3, CR4, R5, Delete R80	11-21-84			
	X3	ADD VR1, DEL. R82, CR13	1-15-85			
	X4	Q8, Q9, C13, C19, C20, C17, C25, C26, R16, R18, R19, R21, R23, R24, R25 DEL. ADD R88	3-7-89			
		ORIGINAL RELEASE	1-3-89			

SPRAGUE OR EQUIV.
503D227F016ND

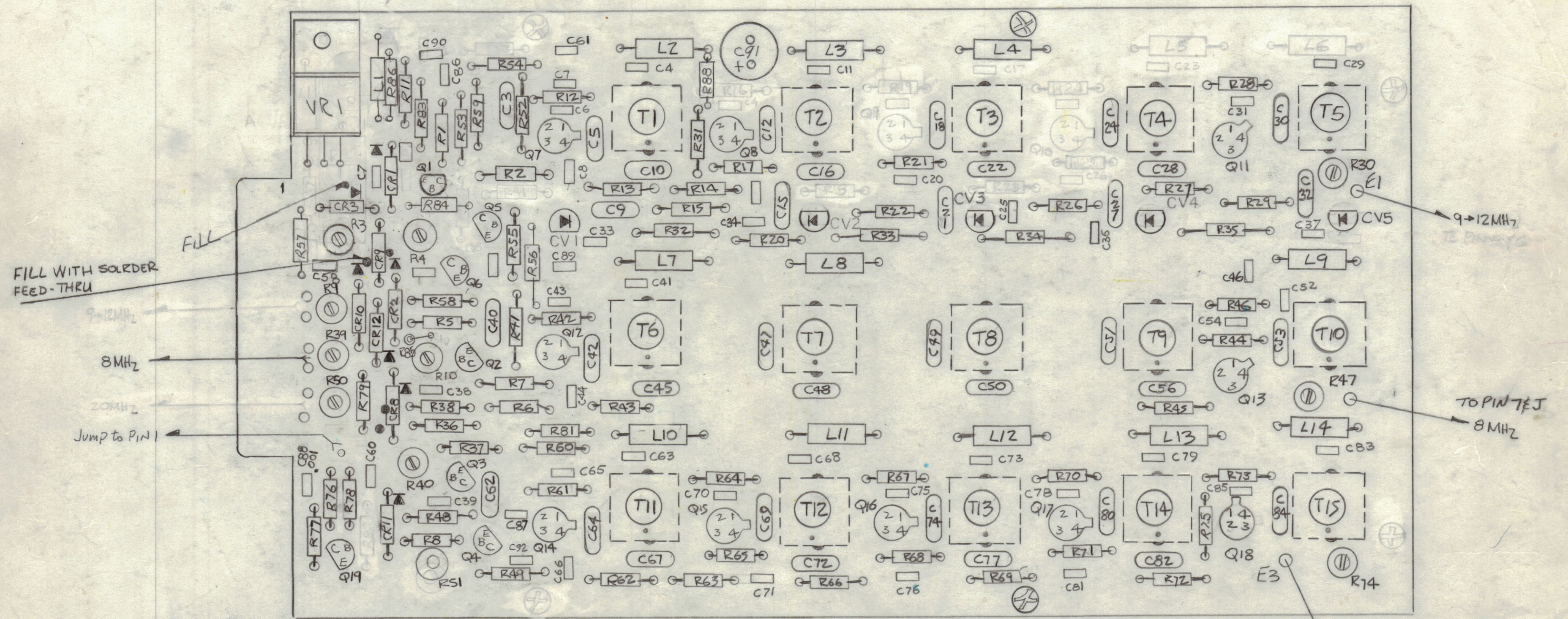

CK2274

QTY / UNIT	MODEL USED ON	ASS'Y NO.
APPLICATION		
CODE		

NOTICE TO PERSONS RECEIVING THIS DRAWING
THE TECHNICAL MATERIEL CORPORATION claims proprietary right in the material disclosed hereon. This drawing is issued in confidence for engineering information only and may not be reproduced or used to manufacture anything shown hereon without permission from THE TECHNICAL MATERIEL CORPORATION to the user. This drawing is loaned for mutual assistance and is subject to recall at any time.

UNLESS OTHERWISE SPECIFIED DIMENSIONS ARE IN INCHES AND INCLUDE CHEMICALLY APPLIED OR PLATED FINISHES

TOLERANCES ON
 DECIMALS .X ± .05
 .XX ± .01
 .XXX ± .005
 FRACTIONS ± 1/64
 ANGLES ± 0° -30'

QTY. REQ.	ITEM	PART NO.	DESCRIPTION	SYMBOL
LIST OF MATERIAL				
FINAL APPROVAL _____ DATE _____ MECH. DES. _____ DATE _____ ELECT. DES. _____ DATE _____ CHECKED _____ DATE _____ DRAWN _____ DATE 12-10-84				
THE TECHNICAL MATERIEL CORP. MAMARONECK, NEW YORK 10MHz SPEC. GENERATOR ASSEMBLY				
SCALE	C	CODE IDENT. NO.	DWG NO.	ISSUE
		82679	A5824	
SHEET				OF