

REVISIONS							
E.M.N. NO.	DRAFT	CHKD	ZONE	LTR	DESCRIPTION	DATE	APPROVED
	<i>[Handwritten]</i>			<i>[Handwritten]</i>	ORIGINAL RELEASE FOR PRODUCTION	1-14-81	

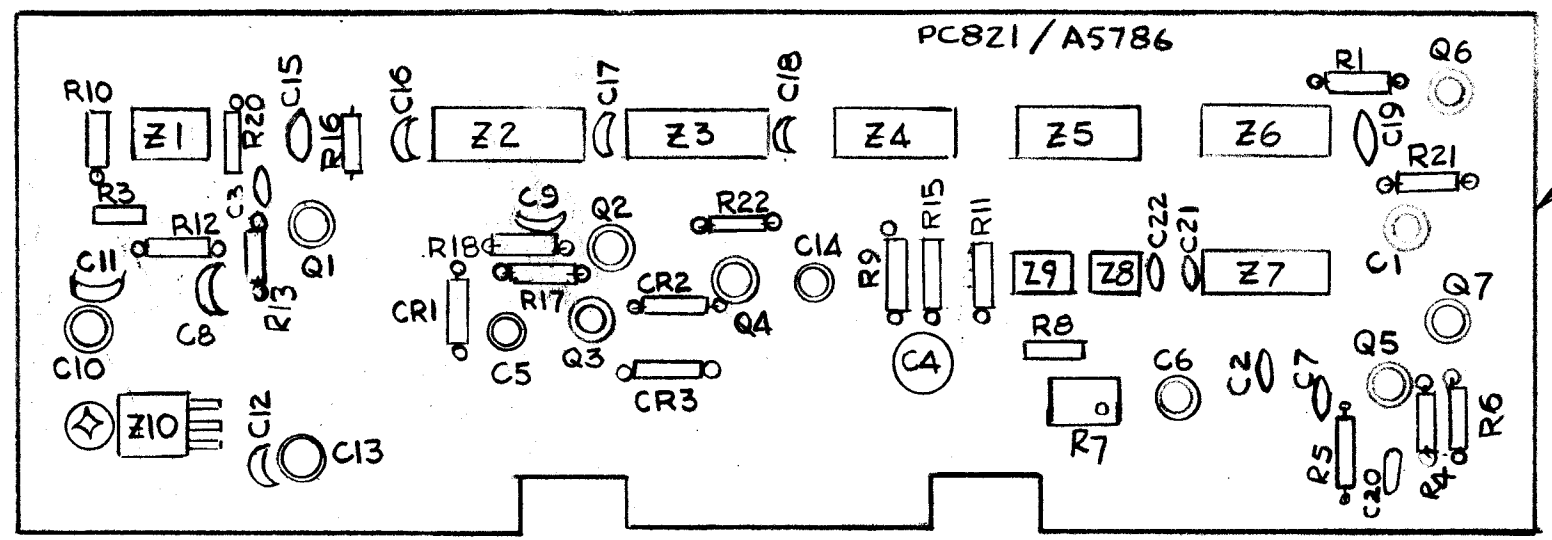

ASSEMBLY NOTES

1. TO MOUNT COMPONENTS INSERT LEADS THROUGH HOLES.
2. CAUTION, WHEN APPLYING HEAT & SOLDER TO LEAD & FOIL.
3. CLEAN & INSPECT AS PER SPEC S676.
4. FOR ELECTRICAL COMPONENT PART NUMBERS REFER TO NPL A
5. USE SYMBOL NUMBERS FOR ASSY. REF.

REQ'D	ITEM	PART NUMBER	DESCRIPTION	SYM.
X	2	BS 100	SOLDER, SOFT	
1	1	PC 821	PRINTED CIRCUIT BD	

LIST OF MATERIAL

QTY / UNIT	MODEL USED ON	ASS'Y NO.
1	GPR-110 C	Z110
APPLICATION		
	CODE	

NOTICE TO PERSONS RECEIVING THIS DRAWING
 THE TECHNICAL MATERIEL CORPORATION claims proprietary right in the material disclosed hereon. This drawing is issued in confidence for engineering information only and may not be reproduced or used to manufacture anything shown hereon without permission from THE TECHNICAL MATERIEL CORPORATION to the user. This drawing is loaned for mutual assistance and is subject to recall at any time.

UNLESS OTHERWISE SPECIFIED DIMENSIONS ARE IN INCHES AND INCLUDE CHEMICALLY APPLIED OR PLATED FINISHES

DECIMALS: .X ± .05, .XX ± .01, .XXX ± .005
 FRACTIONS: 1/64, ANGLES: 0°-30'

MATERIAL: _____
 FINISH: _____

FINAL APPROVAL	DATE
MECH. DES.	DATE
ELECT. DES.	DATE
CHECKED	DATE
DRAWN G.D.L.	DATE 12-26-80

THE TECHNICAL MATERIEL CORP.
 MAMARONECK, NEW YORK

ASSY, PRINTED CIRCUIT BD
 100 HZ SAMPLING PHASE DETECTOR

SIZE B	CODE IDENT. NO. 82679	DWG NO. A 5786	ISSUE <i>[Symbol]</i>
--------	-----------------------	----------------	-----------------------

SCALE 1:1 SHEET OF