

APPLICATION			REVISIONS						
QTY	MODEL USED ON	ASS'Y NO.	LTR	DESCRIPTION	DATE	E.M.N.NO	DRAFT	CHKD	APPD
4	PALA-10K								

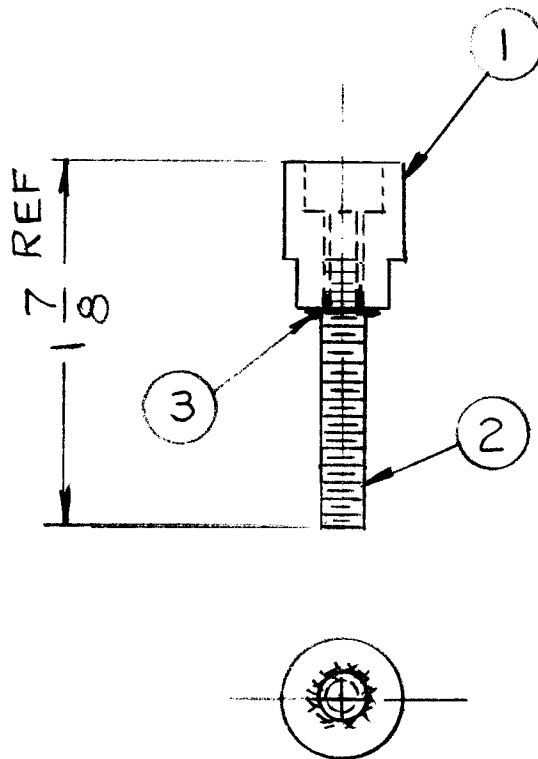

REQ'D	ITEM	PART NUMBER	DESCRIPTION	SYM.
X	3	BS100	SOLDER, TIN ALLOY	
1	2	SMZ520BN1.375	ROD, STUD	
1	1	NT159	NUT, ROUND	

UNLESS OTHERWISE SPECIFIED DIMENSIONS ARE IN INCHES AND INCLUDE CHEMICALLY APPLIED OR PLATED FINISHES

DECIMALS	FRACTIONS
.X ± .05	1/64
.XX ± .01	TOLS. ANGLES
.XXX ± .005	0° - 30°

MATERIAL	—
FINISH	—
	—

FINAL APPROVAL	DATE
MECH. DES.	DATE
ELECT. DES.	DATE
CHECKED	DATE
DRAWN G.D.L	DATE 6-22-72

LIST OF MATERIAL

THE TECHNICAL MATERIEL CORP.  
MAMARONECK, NEW YORK

NUT SHORTING ASS'Y

NOTICE TO PERSONS RECEIVING THIS DRAWING  
THE TECHNICAL MATERIEL CORPORATION claims proprietary right in the material disclosed hereon. This drawing is issued in confidence for engineering information only and may not be reproduced or used to manufacture anything shown hereon without permission from THE TECHNICAL MATERIEL CORPORATION to the user. This drawing is loaned for mutual assistance and is subject to recall at any time.

SIZE A	CODE IDENT. NO. 82679	DWG NO. A 5760	ISSUE
SCALE 1:1		SHEET OF	