

REVISIONS							
E.M.N. NO.	DRAFT	CHKD	ZONE	LTR	DESCRIPTION	DATE	APPROVED
7	MAC			Ø	ORIGINAL RELEASE FOR PRODUCTION	1-7-80	SD

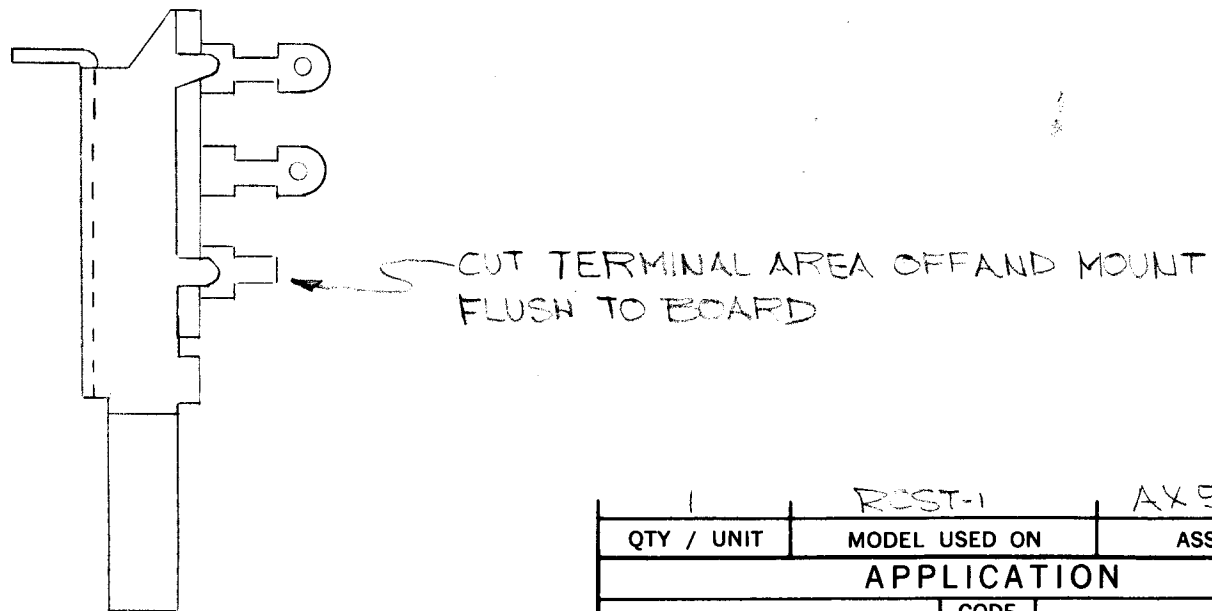
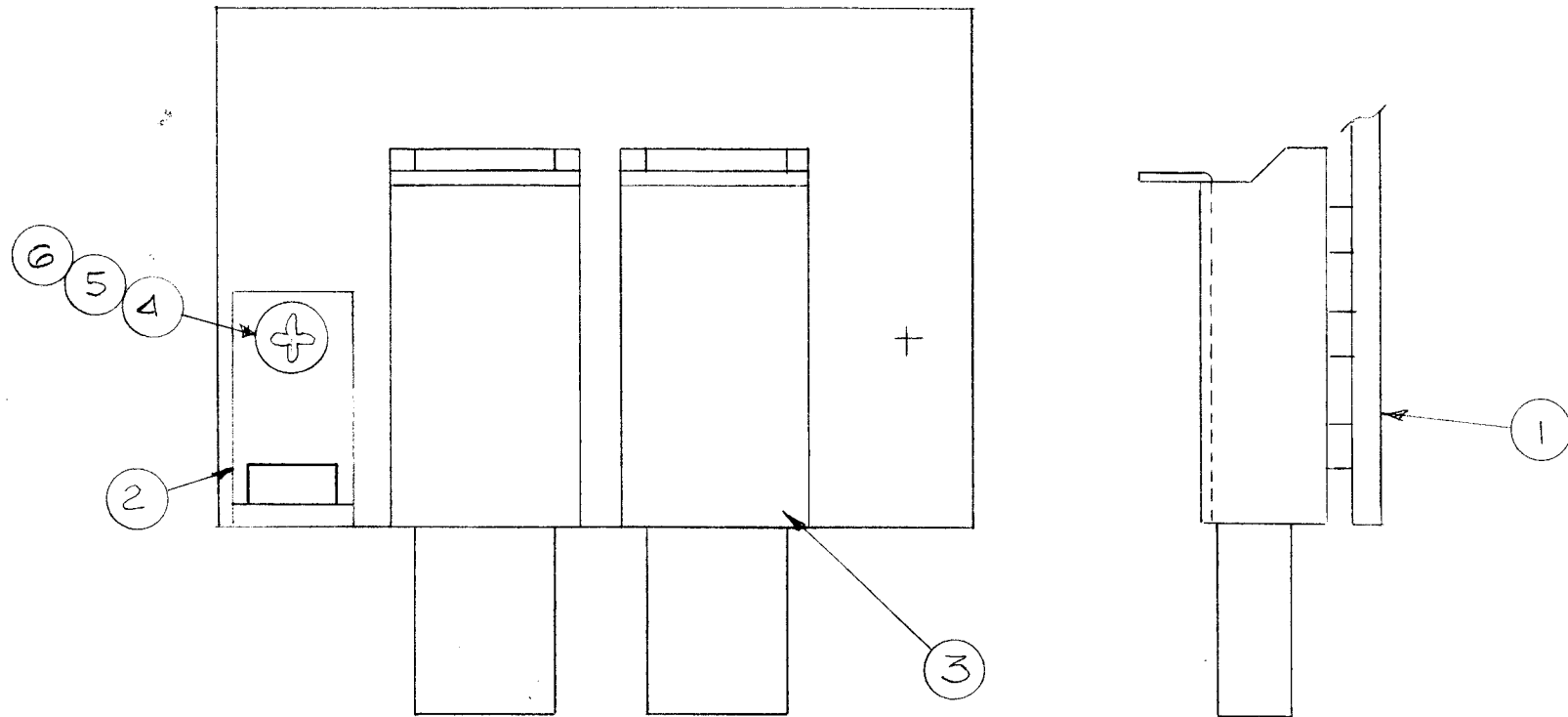

REQ'D	ITEM	PART NUMBER	DESCRIPTION	SYM.
2	6	LW504	LOCKWASHER	
2	5	NTH040BNS	NUT	
2	4	SCBP0440RN5	SCREW	
2	3	SW559-P-1	SWITCH PE PUSH LOCK	
2	2	MS6835-2	BRACKET BD. MTS	
1	1	PC792	PC BD	

LIST OF MATERIAL

1	R0ST-1	AX5224
QTY / UNIT	MODEL USED ON	ASS'Y NO.
APPLICATION		
CODE		

UNLESS OTHERWISE SPECIFIED DIMENSIONS ARE IN INCHES AND INCLUDE CHEMICALLY APPLIED OR PLATED FINISHES		FINAL APPROVAL <i>S.D.</i>	DATE 1/7/80
DECIMALS .X ± .05 .XX ± .01 .XXX ± .005		MECH. DES.	DATE
FRACTIONS 1/64 ANGLES 0° - 30'		ELECT. DES.	DATE
MATERIAL		CHECKED	DATE
FINISH		DRAWN PH	DATE 12-29-77

THE TECHNICAL MATERIEL CORP.
MAMARONECK, NEW YORK

ASSEMBLY PC792

NOTICE TO PERSONS RECEIVING THIS DRAWING
THE TECHNICAL MATERIEL CORPORATION claims proprietary right in the material disclosed hereon. This drawing is issued in confidence for engineering information only and may not be reproduced or used to manufacture anything shown hereon without permission from THE TECHNICAL MATERIEL CORPORATION to the user. This drawing is loaned for mutual assistance and is subject to recall at any time.

SIZE B	CODE IDENT. NO. 82679	DWG NO. A5730	ISSUE Ø
SCALE 2:1		SHEET	OF