

REVISIONS					DATE	APPROVED
E.M.N.O	DRAFT	CHKD	ZONE	LTR	DESCRIPTION	
	PH			X1	ADDED NOTE ON SECOND FIBER WASHER	1-4-78
	GDL			X2	ITEM 7 TEL17-21 DEL. REQ'D ITEM 8 WAS 424 ITEM 2 WAS 7 - ITEM 6 & 13A00	8-15-78
				X3	Assembly Revised and UP-DATED	5-4-81
				Ø	ORIGINAL RELEASE for Production	5-4-81

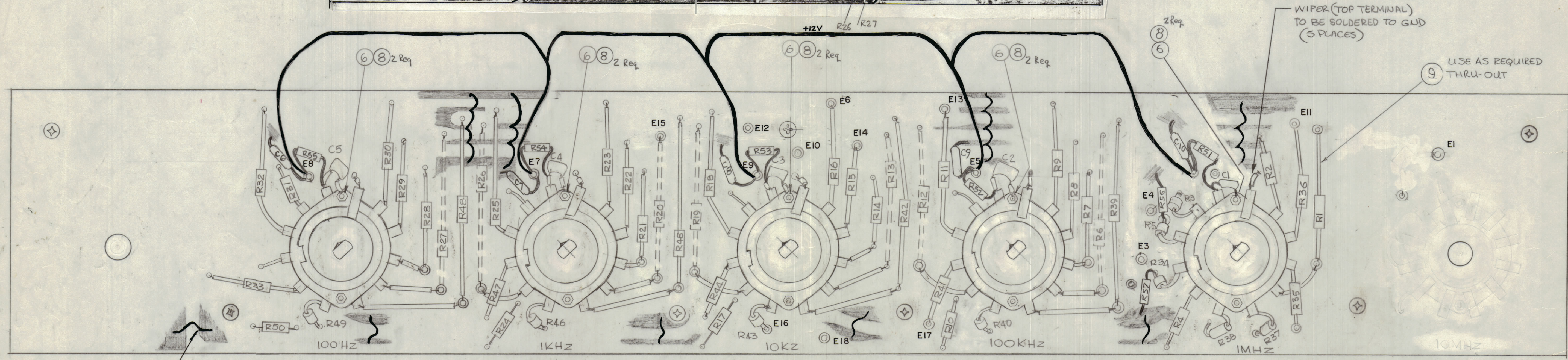

BUS WIRE AS SHOWN
9 PLACES FRONT

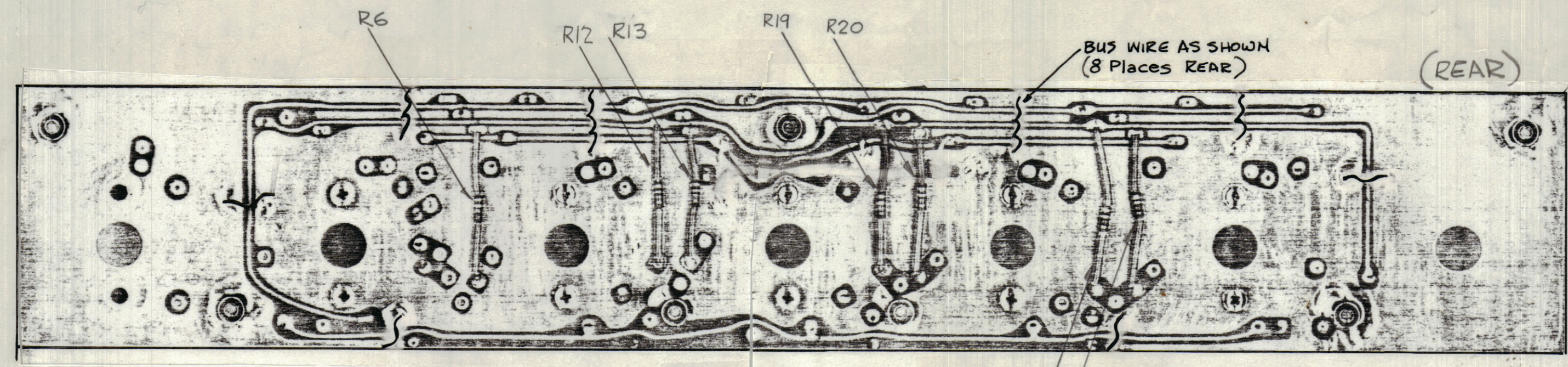
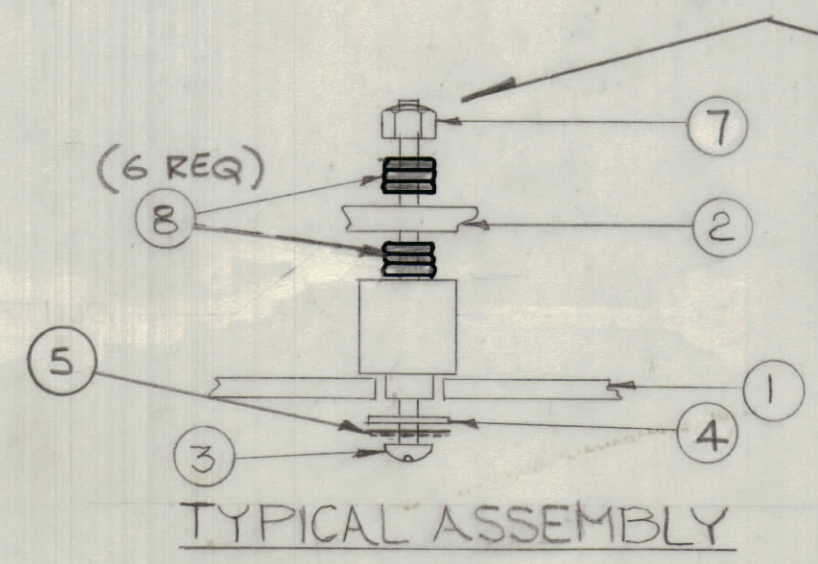
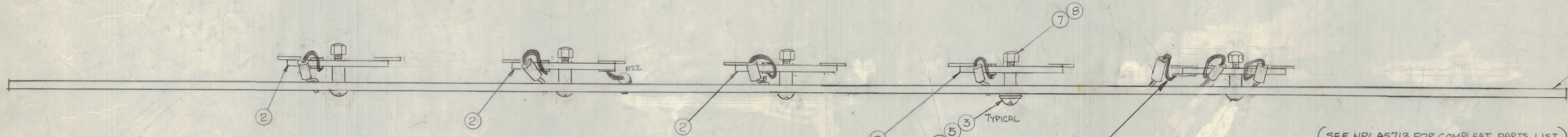

NOTE:
NUT IS NOT DRAWN DOWN TIGHT

ALL CONNECTIONS TO BE
SOLDERED ON THE REAR
TERMINALS EXCEPT FOR
"WIPER TO GND (TOP TERMINAL)"

- ASSEMBLY NOTES**
1. TO MOUNT COMPONENTS INSERT LEADS THROUGH HOLES.
 2. CAUTION, WHEN APPLYING HEAT & SOLDER TO LEAD & FOIL.
 3. CLEAN & INSPECT AS PER SPEC S676.
 4. FOR ELECTRICAL COMPONENT PART NUMBERS REFER TO NPL A
 5. USE SYMBOL NUMBERS FOR ASSY. REF.

QTY. REQ.	ITEM	PART NO.	DESCRIPTION	SYMBOL
AS REQ.	X	9	PX104-3	INSULATION TUBULAR
	58	8	WA109-17	WASHER FIBER
	5	7	SM1273440	NUT LOCK
	5	6	TE115-2	TURRET, INSULATED
	10	5	LWE04LSC	WASHER, LOCK
	10	4	FNO4HB	WASHER, FLAT
	10	3	SCBP440BN12	SCREW, MACHINE
	5	2	WS147	WAFER, SWITCH SIO2A THRU SIO6A
	1	1	PC777	PRINTED CIRCUIT BD

MMX-2B		BMA 535
QTY / UNIT	MODEL USED ON	ASSY NO.
APPLICATION		
CODE		

UNLESS OTHERWISE SPECIFIED DIMENSIONS ARE IN INCHES AND INCLUDE CHEMICALLY APPLIED OR PLATED FINISHES	
TOLERANCES ON	
DECIMALS	FRACTIONS
.X ± .05	± 1/64
.XX ± .01	ANGLES
.XXX ± .005	± 0° -30'

FINAL APPROVAL		DATE
MECH. DES.		DATE
ELECT. DES.		DATE
CHECKED		DATE
DRAWN		DATE
LIST OF MATERIAL		
THE TECHNICAL MATERIEL CORP. MAMARONECK, NEW YORK		
ASSY PRINTED CIRCUIT BD FREQUENCY SWITCHING		
SIZE	CODE IDENT NO.	DWG NO.
D	82679	A5713
SCALE 2:1	SHEET OF	

NOTICE TO PERSONS RECEIVING THIS DRAWING
THE TECHNICAL MATERIEL CORPORATION claims proprietary right in the material disclosed hereon. This drawing is issued in confidence for engineering information only and may not be reproduced or used to manufacture anything shown hereon without permission from THE TECHNICAL MATERIEL CORPORATION to the user. This drawing is loaned for mutual assistance and is subject to recall at any time.