

4

3

2

1

REVISIONS						
ZONE	LTR	DESCRIPTION	DATE	E.M.N.NO	DRAFT	CHKD APPD

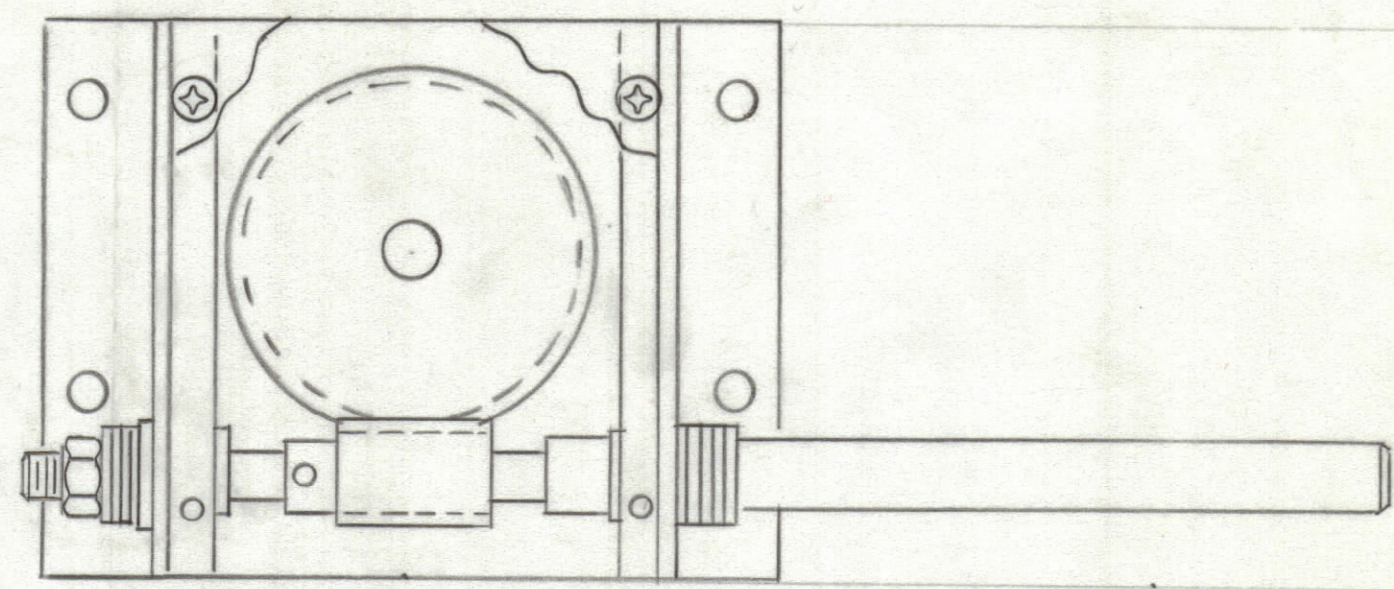
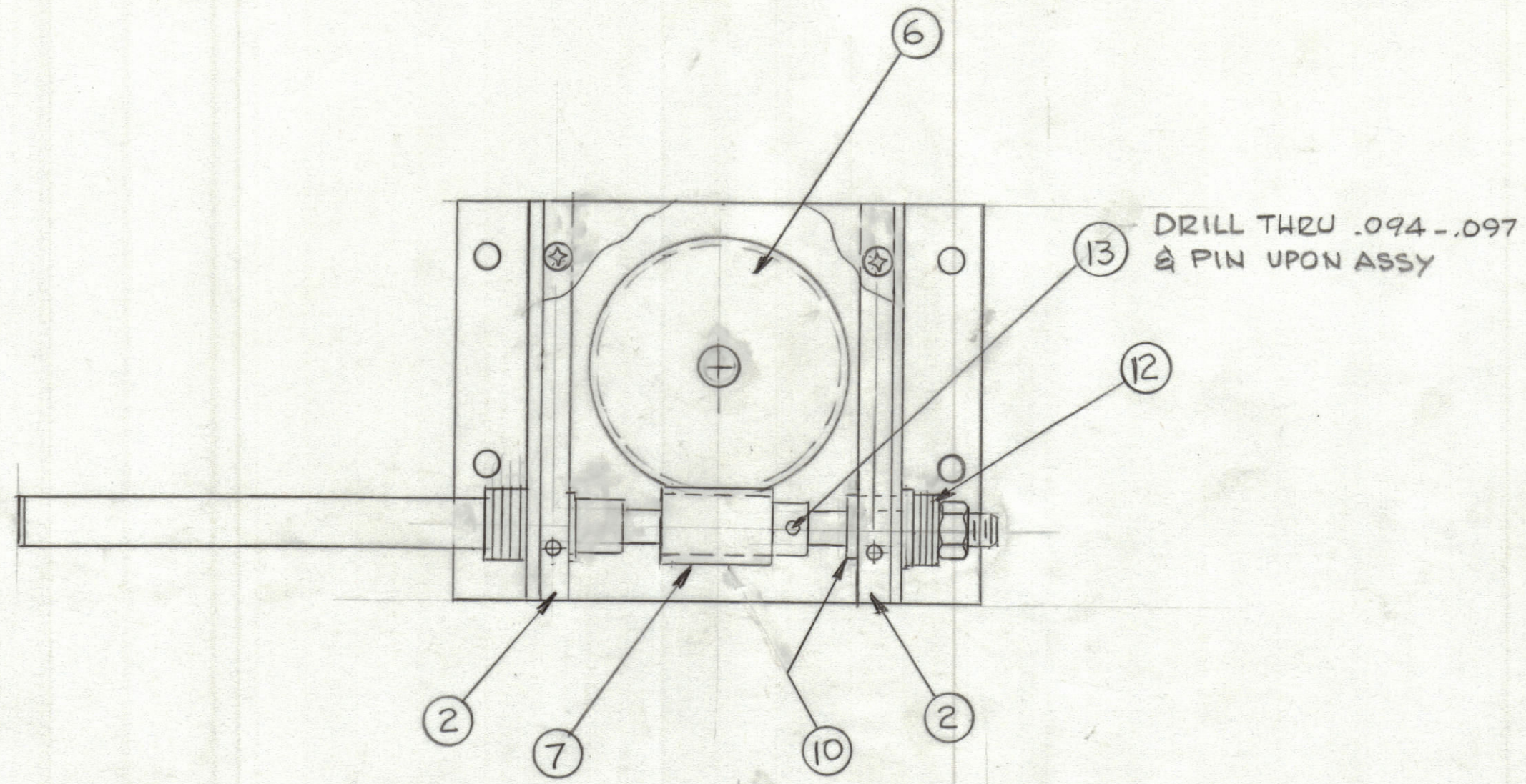

ASSY PER RIGHT DRIVE

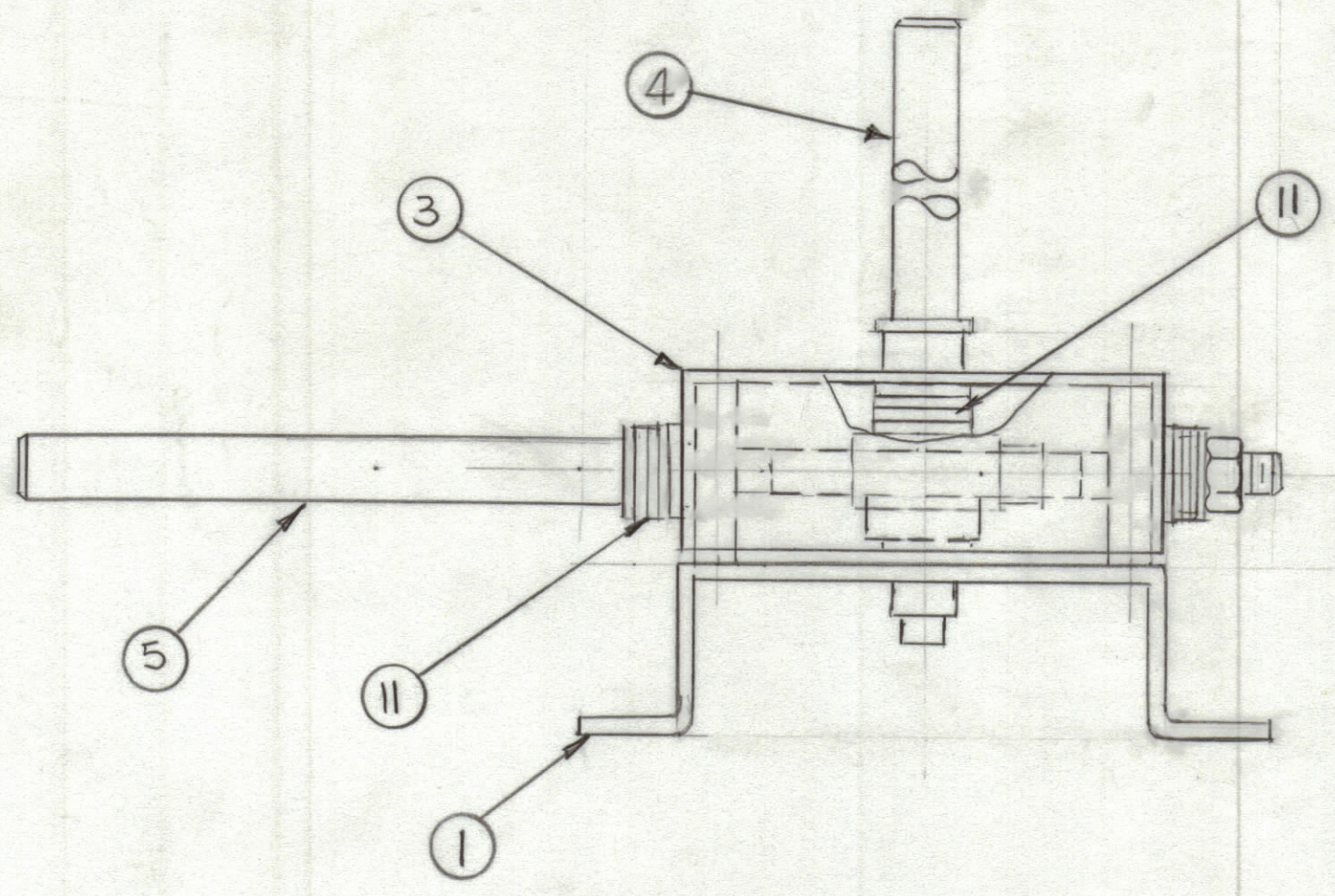

ASSY PER LEFT DRIVE

QTY. REQ.	ITEM	PART NO.	DESCRIPTION	SYMBOL
1	13	PN 79-094-6	PIN, SPRING	
3	12	FW 31 HBN	FLAT WASHER	
6	11	FW 37 LBN	FLAT WASHER	
1	10	BB 118-4	BEARING FLANGE TYPE	
1	9	BB 118-6	BEARING FLANGE TYPE	
1	8	BB 118-8	BEARING FLANGE TYPE	
1	7	GR 227	WORM GEAR	
1	6	GR 226	WHEEL, WORM GEAR	
1	5	PM 1292	SHAFT, WORM WHEEL	
1	4	PM 1291	SHAFT, WORM	
1	3	MS 6792	COVER, GEAR BOX	
2	2	PM 1595	PLATE, MTG BEARING	
1	1	MS 6793	BASE MTG. PLATE	

QTY. REQ.	ITEM	PART NO.	DESCRIPTION	SYMBOL
-----------	------	----------	-------------	--------

LIST OF MATERIAL

2	GPT-10KLF	AX 531
QTY / UNIT	MODEL USED ON	ASS'Y NO.
APPLICATION		
CODE		

NOTICE TO PERSONS RECEIVING THIS DRAWING
 THE TECHNICAL MATERIEL CORPORATION claims proprietary right in the material disclosed hereon. This drawing is issued in confidence for engineering information only and may not be reproduced or used to manufacture anything shown hereon without permission from THE TECHNICAL MATERIEL CORPORATION to the user. This drawing is loaned for mutual assistance and is subject to recall at any time.

UNLESS OTHERWISE SPECIFIED DIMENSIONS ARE IN INCHES AND INCLUDE CHEMICALLY APPLIED OR PLATED FINISHES

TOLERANCES ON	
DECIMALS	FRACTIONS
.X ± .05	± 1/64
.XX ± .01	ANGLES
.XXX ± .005	± 0° -30'

FINAL APPROVAL	DATE
MECH. DES.	DATE
ELECT. DES.	DATE
CHECKED	DATE
DRAWN G.D.L.	DATE 5-13-77

THE TECHNICAL MATERIEL CORP.
 MAMARONECK, NEW YORK

ASSY RT & DRIVE LEFT & RIGHT SIDE

MATERIAL	FINISH	SIZE	CODE IDENT.NO.	DWG NO.	ISSUE
		C	82679	A5703	
SCALE 1" = 1"		SHEET		OF	

4

3

2

1