

5

4

3

2

1

REVISIONS							
E.M.N. NO.	DRAFT	CHKD	ZONE	LTR	DESCRIPTION	DATE	APPROVED
	F.I.			Ø	EXP. RELEASE	3-24-75	
2				Ø	ORIGINAL RELEASE	1-10-77	X

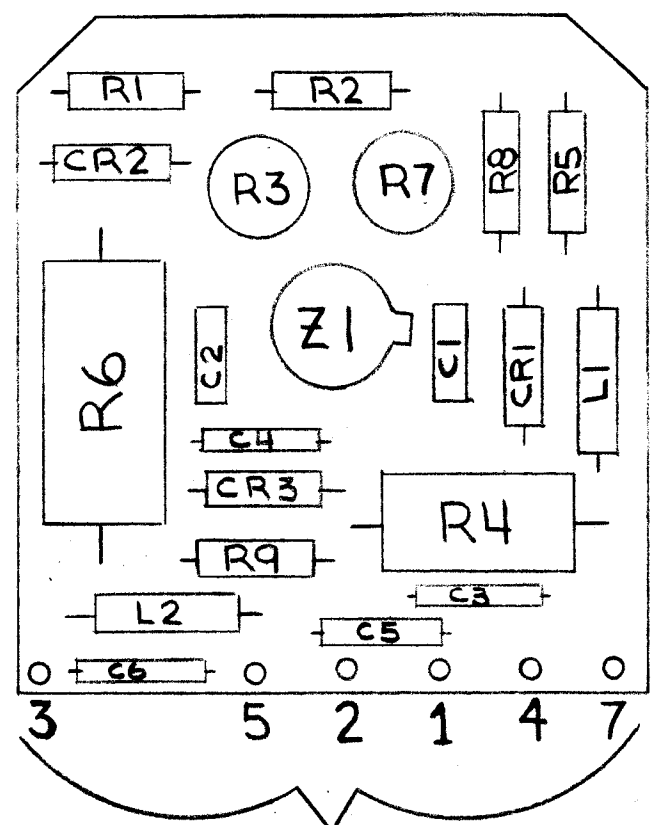

PINS OF SOCKET

ASSEMBLY NOTES

1. TO MOUNT COMPONENTS INSERT LEADS THROUGH HOLES.
2. CAUTION, WHEN APPLYING HEAT & SOLDER TO LEAD & FOIL.
3. CLEAN & INSPECT AS PER SPEC S676.
4. FOR ELECTRICAL COMPONENT PART NUMBERS REFER TO NPL A
5. USE SYMBOL NUMBERS FOR ASSY. REF.

X	2	BS100	SOLDER, TIN/ANTLOY	
1	1	PC	PRINTED CKT BOARD	
REQ'D ITEM	PART NUMBER	DESCRIPTION		SYM.

LIST OF MATERIAL

1	ATLA-2.5K	
QTY / UNIT	MODEL USED ON	ASS'Y NO.
APPLICATION		
	CODE	

NOTICE TO PERSONS RECEIVING THIS DRAWING
 THE TECHNICAL MATERIEL CORPORATION claims proprietary right in the material disclosed hereon. This drawing is issued in confidence for engineering information only and may not be reproduced or used to manufacture anything shown hereon without permission from THE TECHNICAL MATERIEL CORPORATION to the user. This drawing is loaned for mutual assistance and is subject to recall at any time.

UNLESS OTHERWISE SPECIFIED DIMENSIONS ARE IN INCHES AND INCLUDE CHEMICALLY APPLIED OR PLATED FINISHES		FINAL APPROVAL <i>EJB</i>	DATE <i>11/19/77</i>
DECIMALS .X ± .05 .XX ± .01 .XXX ± .005	FRACTIONS 1/64 ANGLES 0°-30'	MECH. DES. F. IANNUZZI	DATE 11-2-74
MATERIAL		ELECT. DES.	DATE
FINISH		CHECKED	DATE
		DRAWN F. IANNUZZI	DATE 3-24-75

THE TECHNICAL MATERIEL CORP. MAMARONECK, NEW YORK			
ASSY. SWR TRIP OUT			
SIZE B	CODE IDENT. NO. 82679	DWG NO. A5624	ISSUE Ø
SCALE 2:1		SHEET OF	

5

4

3

2

1