

REVISIONS						
ZONE	LTR	DESCRIPTION	DATE	E.M.N.NO	DRAFT	CHKD APPD
	A	RELEASED UNDER A REVISION	10-1-76			<i>[Signature]</i> *

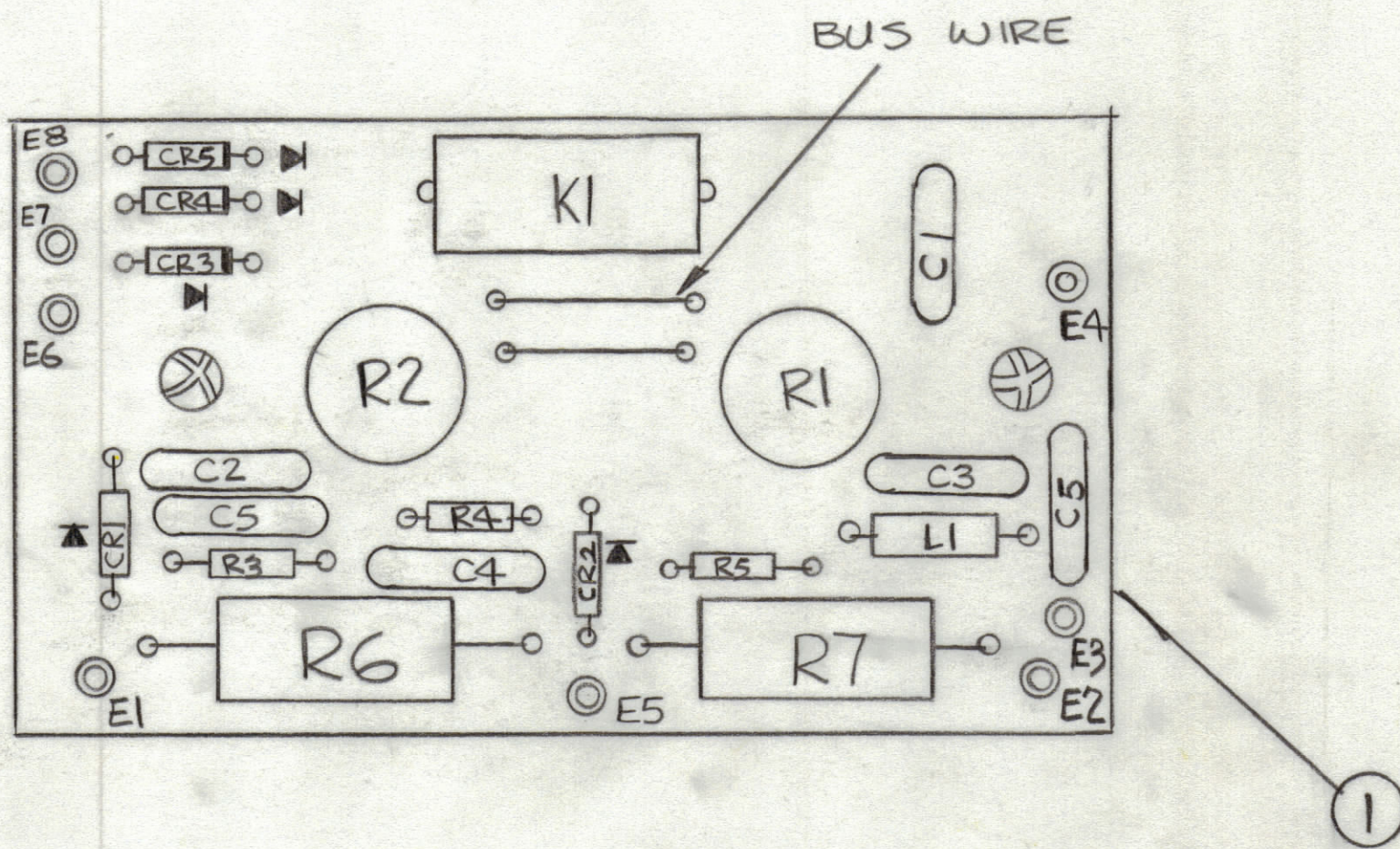

ASSEMBLY NOTES

1. TO MOUNT COMPONENTS INSERT LEADS THROUGH HOLES.
2. CAUTION, WHEN APPLYING HEAT & SOLDER TO LEAD & FOIL.
3. CLEAN & INSPECT AS PER SPEC S676.
4. FOR ELECTRICAL COMPONENT PART NUMBERS REFER TO NPL A
5. USE SYMBOL NUMBERS FOR ASSY. REF.

REF PC729

QTY. REQ.	ITEM	PART NO.	DESCRIPTION	SYMBOL
X	2	BS100	SOLDER, TIN ALLOY	
1	1	PC729	PRINTED CIRCUIT Bd, SENSE	Z102

LIST OF MATERIAL

UNLESS OTHERWISE SPECIFIED DIMENSIONS ARE IN INCHES AND INCLUDE CHEMICALLY APPLIED OR PLATED FINISHES		FINAL APPROVAL * <i>[Signature]</i>	DATE 10-1-76	THE TECHNICAL MATERIEL CORP. MAMARONECK, NEW YORK	
TOLERANCES ON		MECH. DES. <i>[Signature]</i>	DATE 10-1-76		
DECIMALS .X ± .05 .XX ± .01 .XXX ± .005	FRACTIONS ± 1/64 ANGLES ± 0° -30'	ELECT. DES. <i>[Signature]</i>	DATE 10-1-76	ASSY, PRINTED CIRCUIT Bd. SENSE CIRCUIT	
MATERIAL		CHECKED <i>[Signature]</i>	DATE 10-1-76		
FINISH		DRAWN <i>[Signature]</i>	DATE 10-1-76	SIZE C	CODE IDENT.NO. 82679
NOTICE TO PERSONS RECEIVING THIS DRAWING THE TECHNICAL MATERIEL CORPORATION claims proprietary right in the material disclosed hereon. This drawing is issued in confidence for engineering information only and may not be reproduced or used to manufacture anything shown hereon without permission from THE TECHNICAL MATERIEL CORPORATION to the user. This drawing is loaned for mutual assistance and is subject to recall at any time.				DWG NO. A5620	ISSUE A
				SCALE	SHEET OF

1	TMA-1K	BMA520
QTY / UNIT	MODEL USED ON	ASSY NO.
APPLICATION		
CODE		

A5620 A B