

APPLICATION			REVISIONS							
QTY	MODEL USED ON	ASS'Y NO.	LTR	DESCRIPTION	DATE	E.M.N.NO	DRAFT	CHKD	APPD	
1	A5611		X	EXP. RELEASE						
			Ø	ORIG RELEASE FOR PROD	3/13/75		CL.			

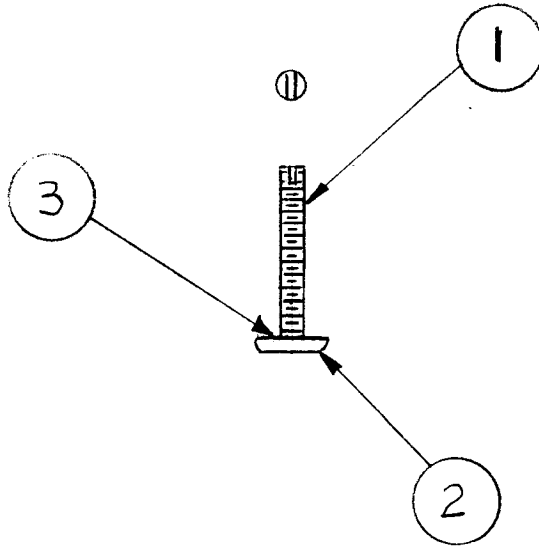

X	3	BS100	SOLDER, TIN ALLOY	
1	2	MS6574-1	PLATE CAPACITOR	
1	1	SCFP0632BN14	SCREW MACHINE FLAT HEAD	

UNLESS OTHERWISE SPECIFIED DIMENSIONS ARE IN INCHES AND INCLUDE CHEMICALLY APPLIED OR PLATED FINISHES

REQ'D	ITEM	PART NUMBER	DESCRIPTION	SYM.
-------	------	-------------	-------------	------

LIST OF MATERIAL

DECIMALS	FRACTIONS
.X ± .05	1/64
.XX ± .01	TOLS. ANGLES
.XXX ± .005	9° - 30°

FINAL APPROVAL	DATE
<i>[Signature]</i>	3/13/75

THE TECHNICAL MATERIEL CORP.
MAMARONECK, NEW YORK

MATERIAL	MECH. DES.	DATE
	F. IANNUZZI	2-7-75
FINISH	ELECT. DES.	DATE

ASS'Y PISTON CAPACITOR

	CHECKED	DATE
	F. IANNUZZI	12-14-74
	DRAWN	DATE
	G. DELUCIA	

--	--	--

NOTICE TO PERSONS RECEIVING THIS DRAWING
THE TECHNICAL MATERIEL CORPORATION claims proprietary right in the material disclosed hereon. This drawing is issued in confidence for engineering information only and may not be reproduced or used to manufacture anything shown hereon without permission from THE TECHNICAL MATERIEL CORPORATION to the user. This drawing is loaned for mutual assistance and is subject to recall at any time.

SIZE	CODE IDENT. NO.	DWG NO.	ISSUE
A	82679	A5612	Ø
SCALE	1:1	SHEET	OF