

IF IT IS FOUND DESIRABLE TO CHANGE ANY TOLERANCE OR OTHER DETAIL SPECIFIED ON THIS DRAWING NOTIFY THE PURCHASER PROMPTLY.

MAXIMUM ALLOWABLE TOLERANCES HAVE BEEN DETERMINED AND DEVIATIONS WILL BE CAUSE FOR REJECTION. REMOVE ALL BURRS AND SHARP EDGES

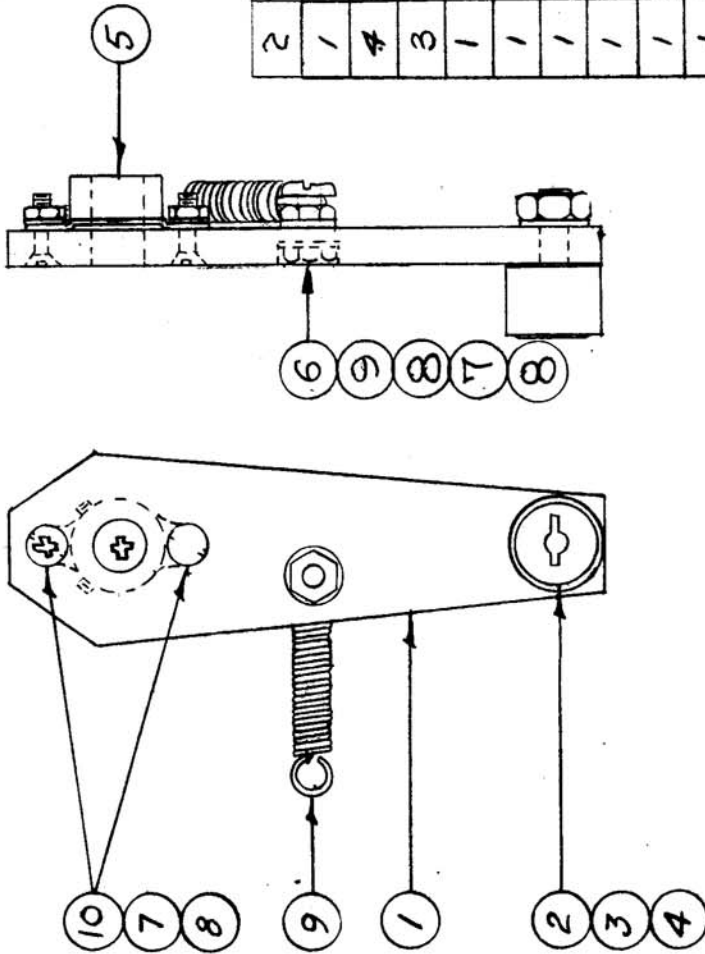

A-583 F

USED ON

QUAN. PER UNIT	MODEL	PROJECT NO.	ASSY. NO.	DATE
1	VOX	101	A-585	11-10-53
1	PMO-2	285		8/17/54
1	VOX-2	291		1/27/55
1	RTF			2-2-56
1	RTF-2			11-10-58
1	AO-100		A-174Z	
1	VOX, 3,4,5,6			5-21-62

REQ. ITEM	ITEM	PART NO.	DESCRIPTION	SYMBOL
2	10	SCFP0440BNG	SCREW, MACHINE	
1	9	SP-113	SPRING, CAM FOLLOWER	
4	8	NTH0440BNG	NUT, HEX.	
3	7	LW504MRN	LOCKWASHER, SPLIT	
1	6	SCBP0440BNG	SCREW, MACH.	
1	5	MC-105-1	COUPLING	
1	4	NTH032BN/2	NUT, HEX.	
1	3	LWEI0MRN	LOCKWASHER, INT.	
1	2	BB-107	BEARING, CAM FOLLOWER, MOD.	
1	1	PX-165	CAM FOLLOWER ARM	

ISSUE ITEM	CHANGED FROM	DATE	CN. NO.	DRAFTS	CHECKER/ENG. APP.
E	QTY ITEM 7 WAS 2	12/24/62	17567	WHD	
E	BUILDUP REVISED	6/21/62	6470	DBM	
D	ITEM 2 WAS BB-112	10/6/56	4	COB	
C	SPRING POS. CHANGED	3/20/62	3	COB	
B	ITEM 2 WAS BB-107	7/11/55	2	COB	
A	ITEM 6 WAS SCFS	7/11/55	1	COB	

THE TECHNICAL MATERIEL CORP.	NEW YORK
MAMARONECK.	
CAM FOLLOWER ARM SUB ASSY.	
(OSC ASSY.)	
11-10-53	AJJ
DRAWN	ELEC. DES. APP.
CHECKED	MECH. DES. APP.
FINAL APPROVAL	
A-583	F

SCALE FULL  
 DRILL, PUNCH, COMMERCIAL STOCK SIZES AND MANUFACTURERS TOLERANCES ARE NOT INCLUDED.