

IF IT IS FOUND DESIRABLE TO CHANGE ANY TOLERANCE OR OTHER DETAIL SPECIFIED ON THIS DRAWING NOTIFY THE PURCHASER PROMPTLY.

MAXIMUM ALLOWABLE TOLERANCES HAVE BEEN DETERMINED AND DEVIATIONS WILL BE CAUSE FOR REJECTION. REMOVE ALL BURRS AND SHARP EDGES

A-501

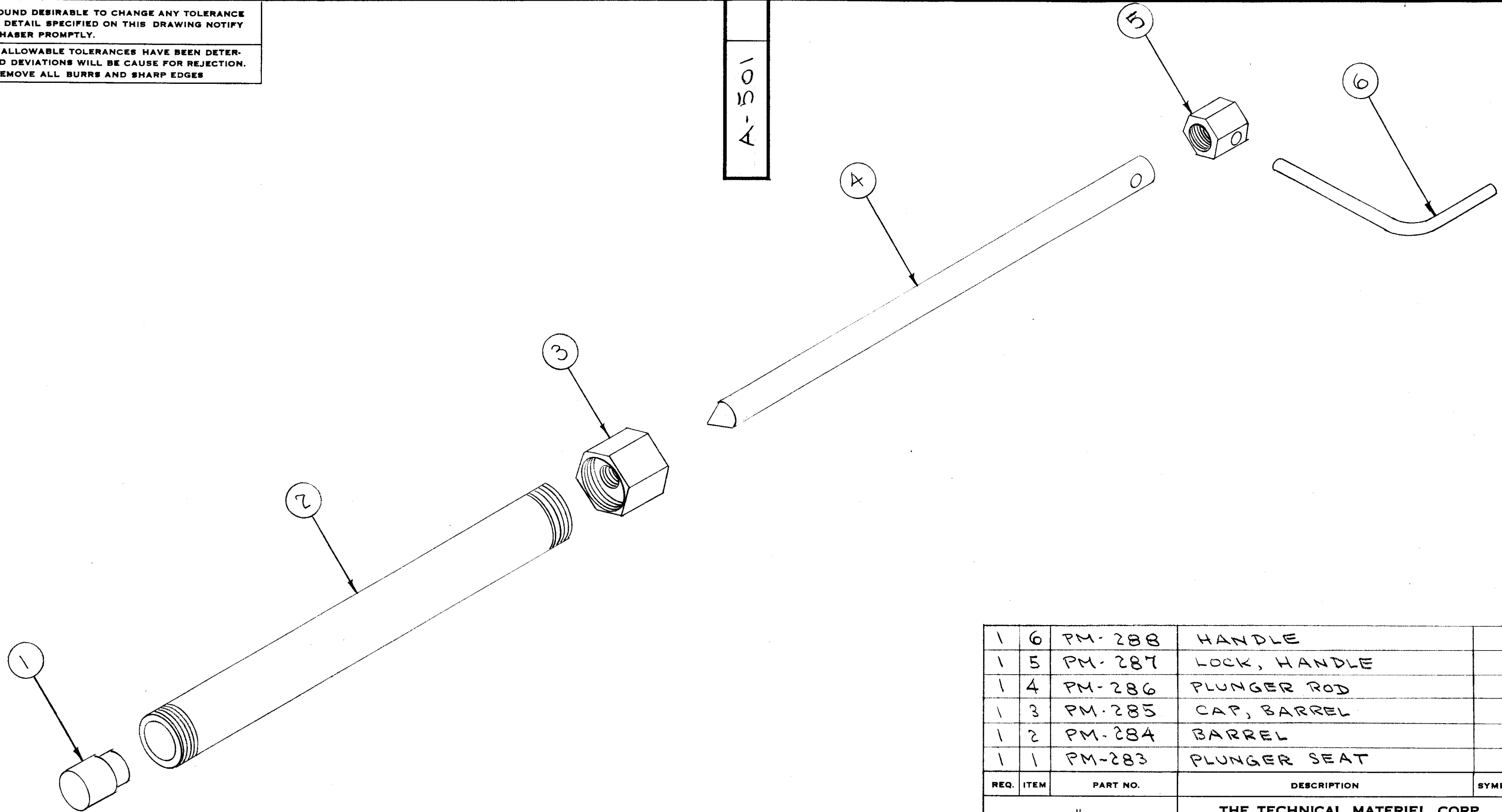

1	6	PM-288	HANDLE	
1	5	PM-287	LOCK, HANDLE	
1	4	PM-286	PLUNGER ROD	
1	3	PM-285	CAP, BARREL	
1	2	PM-284	BARREL	
1	1	PM-283	PLUNGER SEAT	
REQ.	ITEM	PART NO.	DESCRIPTION	SYMBOL
			THE TECHNICAL MATERIEL CORP. MAMARONECK, NEW YORK	
STOCK SIZE			INJECTION GUN ASSEMBLY	
MATERIAL		WEIGHT PER PC.		
TYPE & TEMPER			C.D.D. 4-27-54	
HEAT TREAT. SPEC.			DRAWN	MECH. DES. APP.
FINISH & SPEC. NO.			CHECKED	FINAL APPROVAL

ISSUE	ITEM	CHANGED FROM	DATE	CN. NO.	DRAFTS	CHECKER	ENG. APP.
TOLERANCES		SCALE: #					
ALL OTHERS	DEC. DIM. ± FRAC. DIM. ± ANGULAR DIM. ±	DRILL, PUNCH, COMMERCIAL STOCK SIZES AND MANUFACTURERS TOLERANCES ARE NOT INCLUDED.					

1	KS-85-X	J-227		4-27-54
REQ. PER UNIT	MODEL	PROJECT NO.	ASS'Y. NO.	DATE
USED ON				