

5

4

3

2

1

REVISIONS						
ZONE	LTR	DESCRIPTION	DATE	E.M.N.NO	DRAFT	CHKD APPD
	A	REDRAW FRM PHOTO	10/23/70	20049	GE	CU J.E.B
	B	ADD TABS TO Z1-Z5	4/17/72	20121A	GE	ES EG

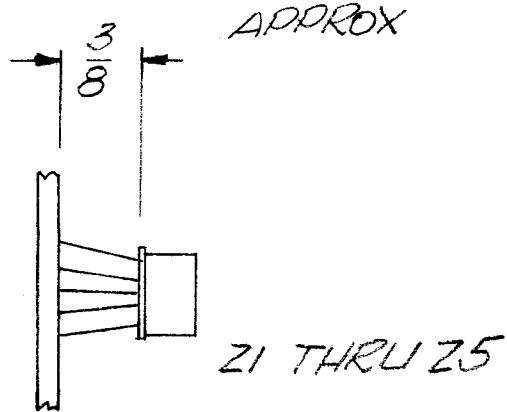
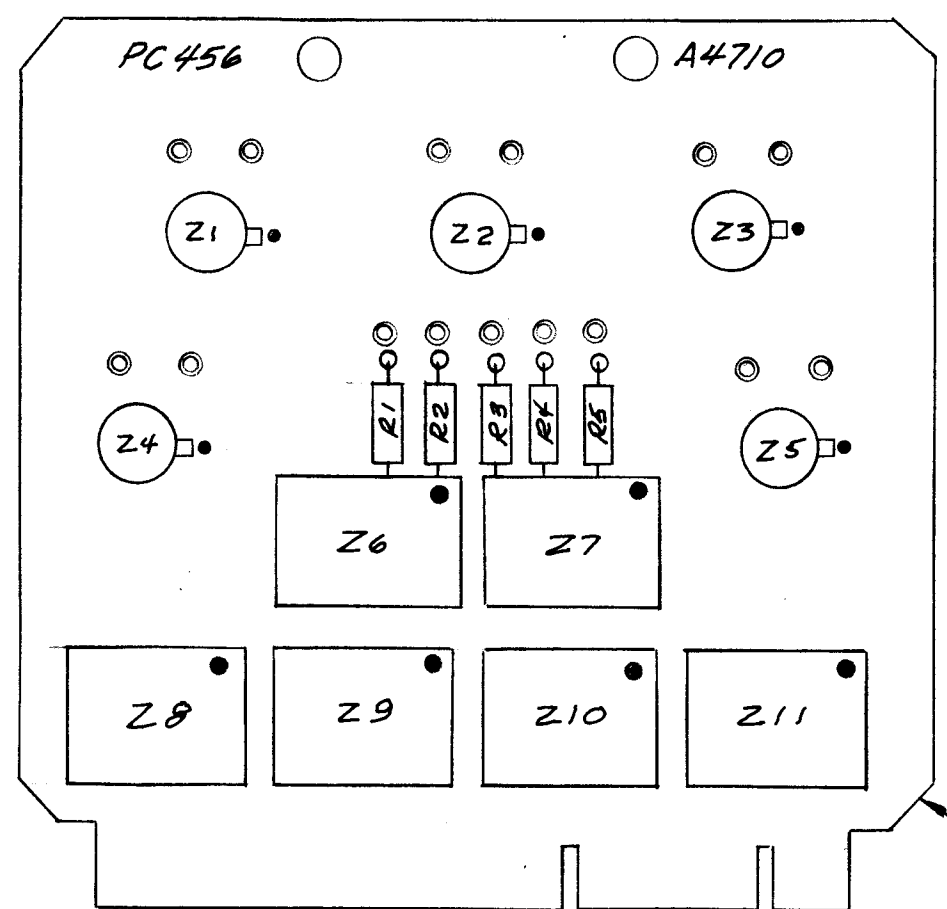

**ASSEMBLY NOTES**

1. TO MOUNT COMPONENTS INSERT LEAD THROUGH PLATED THRU-HOLES.
2. CAUTION: WHEN APPLYING HEAT AND SOLDER TO LEAD AND FOIL.
3. CLEAN AND INSPECT AS PER TMC SPEC S676.
4. FOR ELECTRICAL COMPONENT PART NUMBERS REFER TO NPL A4710.
5. USE SYMBOL NUMBERS FOR ASSEMBLY REFERENCE

REQ'D	ITEM	PART NUMBER	DESCRIPTION	SYM.
X	2	BS 100	SOLDER TIN	
1	1	PC 456	P.C. BOARD	

**LIST OF MATERIAL**

RTML-4142		
QTY / UNIT	MODEL USED ON	ASS'Y NO.
APPLICATION		
CODE		

**NOTICE TO PERSONS RECEIVING THIS DRAWING**  
 THE TECHNICAL MATERIEL CORPORATION claims proprietary right in the material disclosed hereon. This drawing is issued in confidence for engineering information only and may not be reproduced or used to manufacture anything shown hereon without permission from THE TECHNICAL MATERIEL CORPORATION to the user. This drawing is loaned for mutual assistance and is subject to recall at any time.

UNLESS OTHERWISE SPECIFIED DIMENSIONS ARE IN INCHES AND INCLUDE CHEMICALLY APPLIED OR PLATED FINISHES		FINAL APPROV. S. DEMARCO	DATE
MECH. DES. R0220		CHECKED CU	DATE
ELECT. DES.		DRAWN GE	DATE 10/23/70
MATERIAL		FINISH	

THE TECHNICAL MATERIEL CORP. MAMARONECK, NEW YORK			
PC 456 ASSY. MEMORY, CIRCUIT			
SIZE B	CODE IDENT. NO.	DWG NO. A 4710	ISSUE B
SCALE	SHEET OF		1

A

A

B

B

C

C

D

D