

REVISIONS						
ZONE	LTR	DESCRIPTION	DATE	E.M.N.NO	DRAFT	CHKD APPD
	A	REDRAWN	9/23/70	19988	GE	CV JD

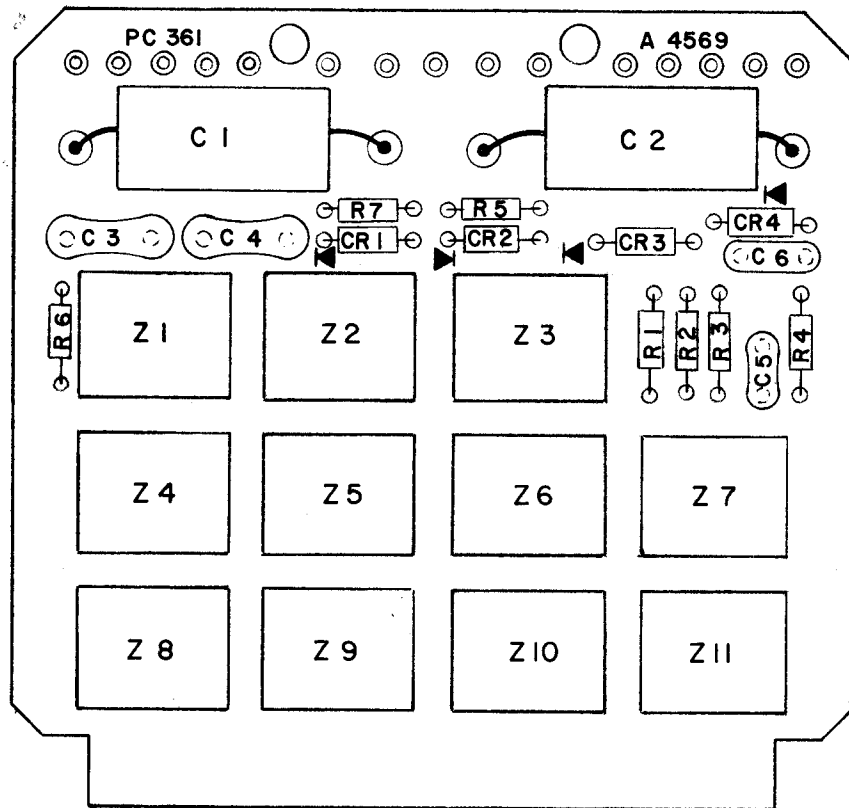

ASSEMBLY NOTES

1. TO MOUNT COMPONENTS INSERT LEAD THROUGH PLATED THRU HOLES.
2. CAUTION: WHEN APPLYING HEAT AND SOLDER TO LEAD AND FOIL.
3. CLEAN AND INSPECT AS PER TMC SPEC. 5676.
4. FOR ELECTRICAL COMPONENT PART NUMBERS REFER TO NPL A 4569.
5. USE SYMBOL NUMBERS FOR ASSEMBLY REFERENCE.

REQ'D	ITEM	PART NUMBER	DESCRIPTION	SYM.
1	1	PC 361	PRINTED CIRCUIT BD.	

LIST OF MATERIAL

UNLESS OTHERWISE SPECIFIED DIMENSIONS ARE IN INCHES AND INCLUDE CHEMICALLY APPLIED OR PLATED FINISHES		FINAL APPROVAL <i>S. J. ...</i> MECH. DES. <i>R. U. ...</i>	DATE 9/30/70 DATE 9-30-70	THE TECHNICAL MATERIEL CORP. MAMARONECK, NEW YORK
DECIMALS .X ± .05 .XX ± .01 .XXX ± .005	FRACTIONS 1/64 ANGLES 0° -30'	ELECT. DES. CHECKED <i>Clelia</i>	DATE 9/30/70	
APPLICATION		DRAWN <i>EVANGELIST</i>		DATE 9/23/70

QTY / UNIT	MODEL USED ON	ASS'Y NO.
	RTMU-41( )	
APPLICATION		
CODE	S 401-451	
A		

**NOTICE TO PERSONS RECEIVING THIS DRAWING**  
 THE TECHNICAL MATERIEL CORPORATION claims proprietary right in the material disclosed hereon. This drawing is issued in confidence for engineering information only and may not be reproduced or used to manufacture anything shown hereon without permission from THE TECHNICAL MATERIEL CORPORATION to the user. This drawing is loaned for mutual assistance and is subject to recall at any time.

SIZE	CODE IDENT. NO.	DWG NO.	ISSU
B	82679	A 4569	A
SCALE 1:1		SHEET	OF