

HOLE	DESCRIPTION	REQ
A	.062-.065 DIA	3
B	.187 DIA. HOLE C'BORE .281 DIA .046 $\pm .010$ DEEP	3

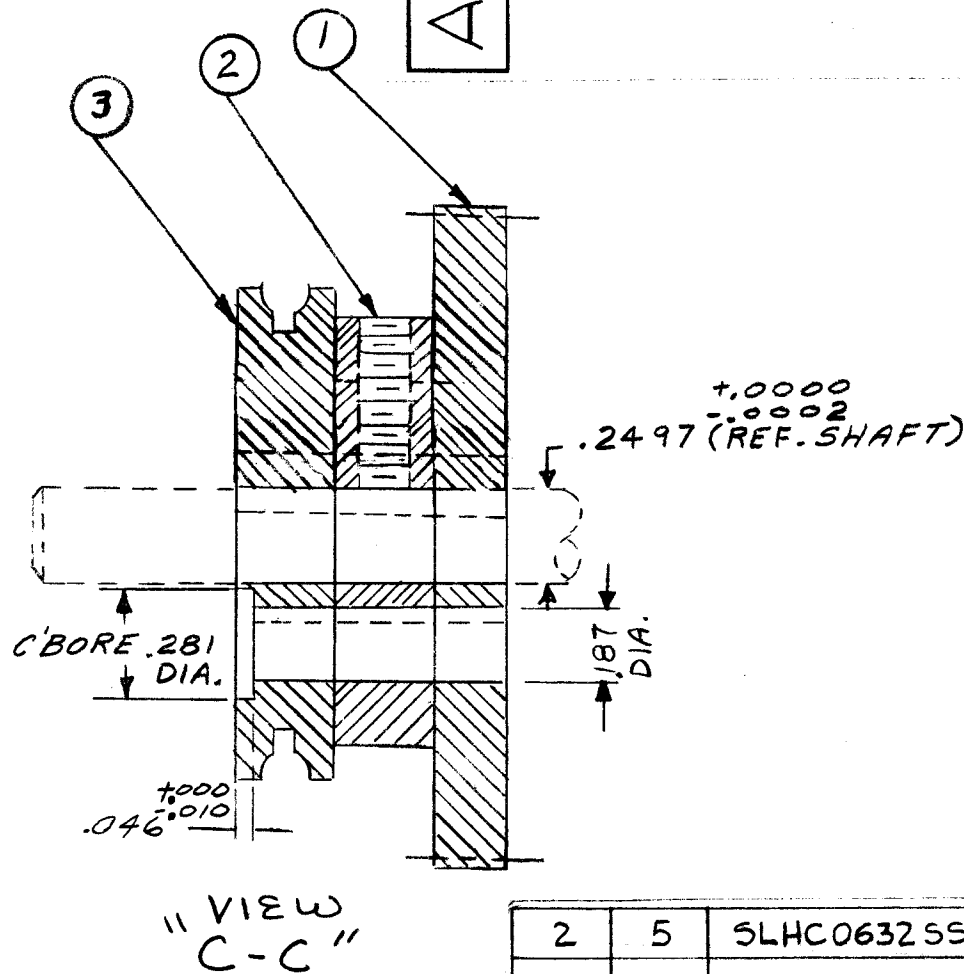
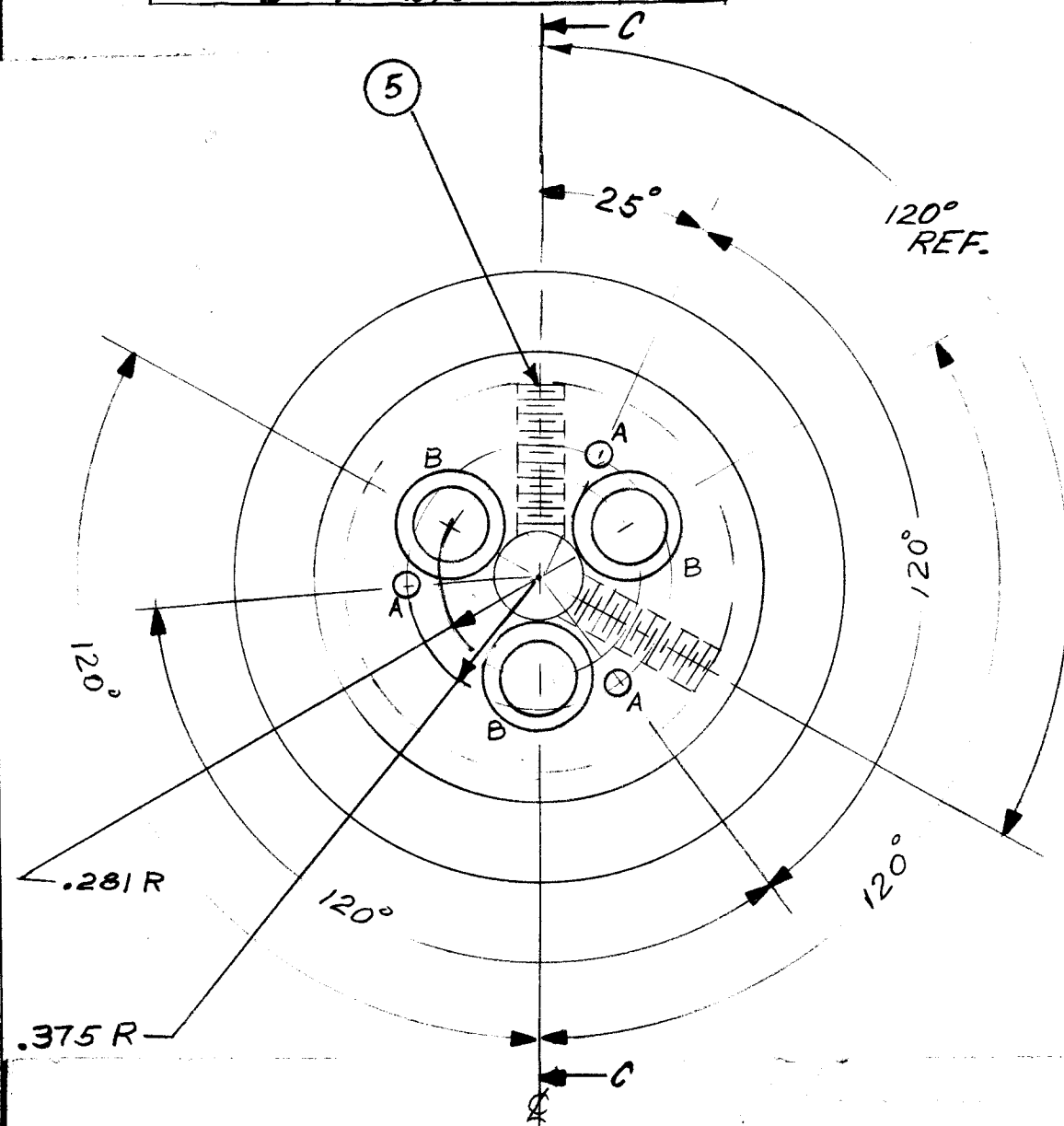

A
A4175

REVISIONS					
SYM	DESCRIPTION	DATE	E.M.N. NO.	DRAFT	CHKD APPD
X	EXPER. RELEASE	1-29-65		G.D.L	
X1	DIA. B HOLE WAS .087	4-20-65		G.D.L	AK
Ø	ORIGINAL RELEASE FOR PRODUCTION	4-20-65		G.D.L	
A	REVISED COMPLETELY	19/1/65	14960	NYC	HQ

NOTE:

- 1 - LINE UP ITEMS 1, 2, AND 3 WITH .2497 DIA. SHAFT
- 2 - DRILL HOLES "A" & "B"
- 3 - PIN THROUGH "A" HOLES WITH ITEM 4

REQ'D.	ITEM	PART NUMBER	DESCRIPTION	SYMBOL
2	5	SLHC0632554	SET SCREW	
3	4	PN59-062-11	PIN, SPRING	
1	3	PM1043	SPROCKET WHEEL	
1	2	PM1031	PLATE, SPACER	
1	1	GR 217-1	GEAR, SPUR	

J. ANGER		LIST OF MATERIAL	
MATERIAL	#	THE TECHNICAL MATERIEL CORP. MAMARONECK, NEW YORK	
FINISH	#	TITLE GEAR & SPROCKET ASSY	

1	CHG-3/CHGR-3	AX 547-
Q'TY./UNIT	MODEL USED ON	ASS'Y. NO.
SCALE	CODE	
2:1	A	
THE CONTENTS OF THIS DRAWING ARE THE EXCLUSIVE PROPERTY OF THE TECHNICAL MATERIEL CORP. ITS UNAUTHORIZED USE OR REPRODUCTION IN WHOLE OR IN PART IS STRICTLY FORBIDDEN.		

UNLESS OTHERWISE SPECIFIED DIMENSIONS ARE IN INCHES AND INCLUDE CHEMICALLY APPLIED OR PLATED FINISHES		DRAWN	G.D.L	DATE	2-3-65	FINAL APPROVAL		DATE	
DECIMALS	TOLERANCES	FRACTIONS		CHECKED	AK	DATE	4/20/65		
.X ± .05		± 1/64		ELECT. DES.	J. Anger	DATE	4/20/65		
.XX ± .01		ANGLES	± 0° 30'	MECH. DES.		DATE			
.XXX ± .005									

NOTES

A 4175		REV. LTR.	A
SHEET			