

REVISIONS							
ZONE	SYM	DESCRIPTION	DATE	E.M.N. NO.	DRAFT	CHKD	APPD
		ORIGINAL RELEASE FOR PRODUCTION	4.11.69		BN		

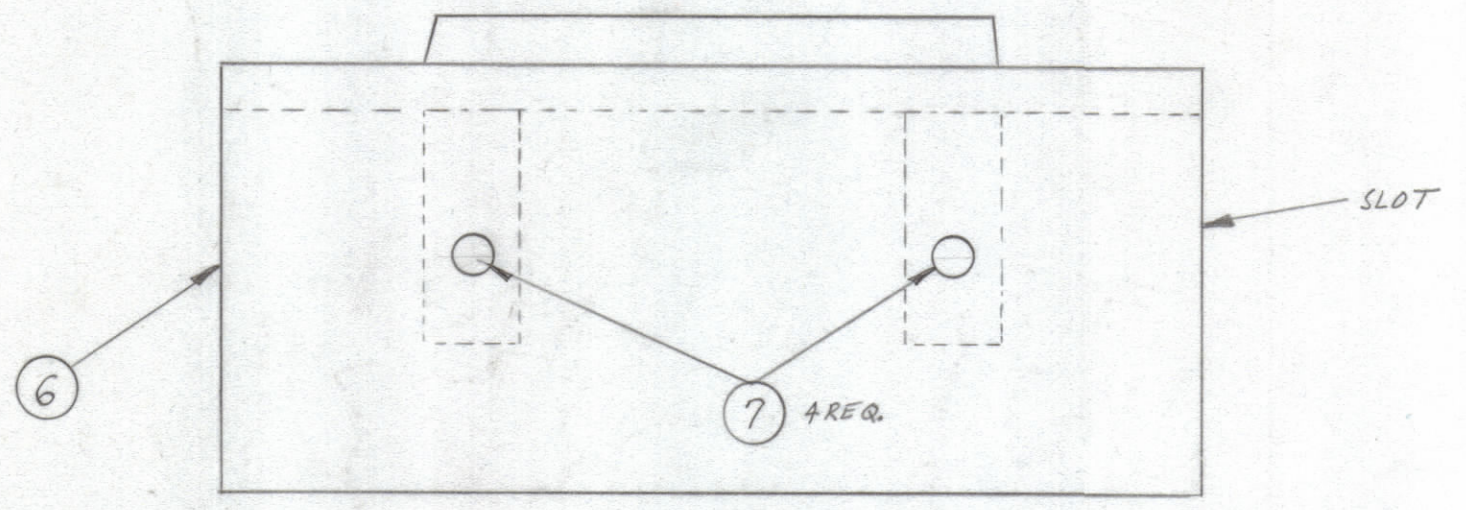
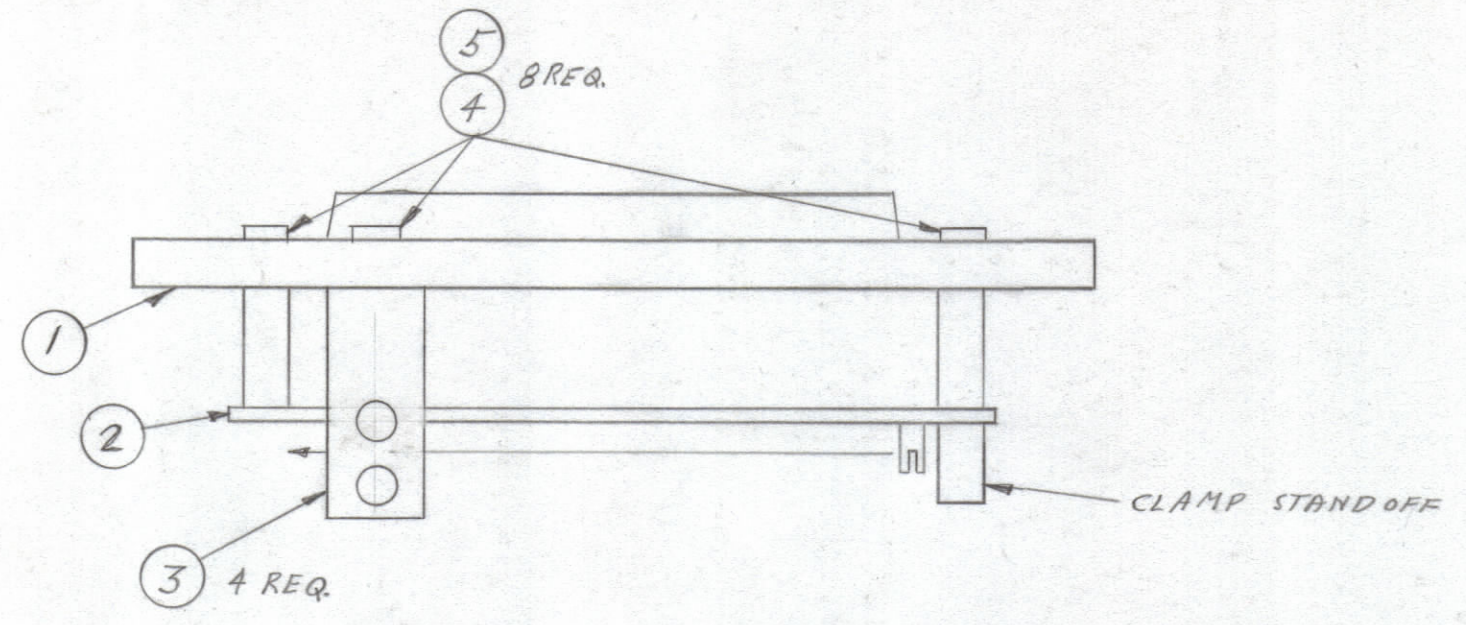
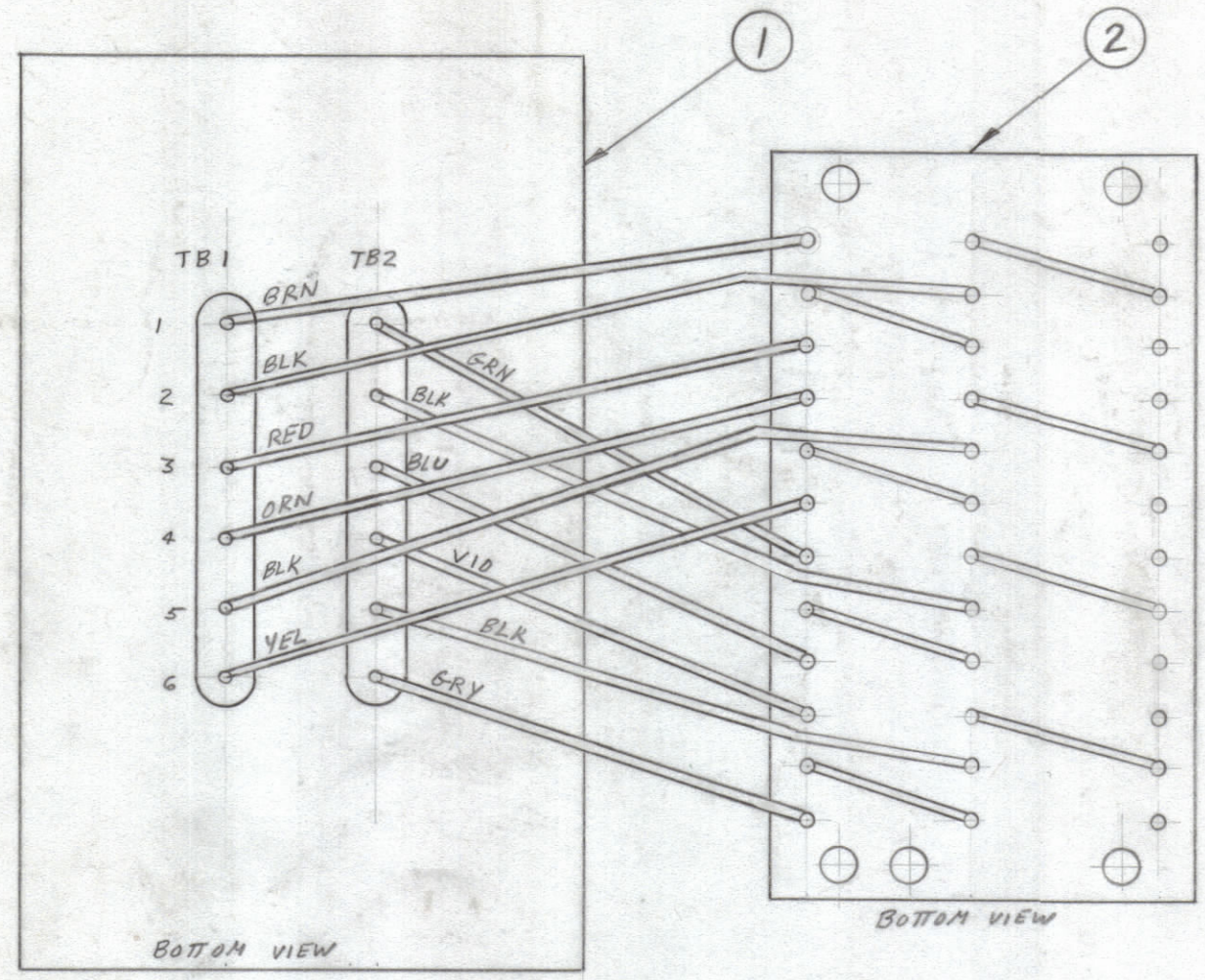

NOTE: ITEM 1 MOUNTED IN ITEM 6 WITH CLAMP STAND OFF FACING SLOT.

15			
14			
13			
12			
11			
10			
9			
8	BS100	SOLDER, TIN ALY	
4	7 SCBPO632 BN4	SCREW, MACHINE	
1	6 MS4180	CHASSIS, ELECTRICAL	
8	5 LWED6 HRN	LOCK WASHER, EXTERNAL	
8	4 SCBPO632 BN8	SCREW, MACHINE	
4	3 MS3665	BRACKET, MOUNTING	
1	2 A4077	ASSEMBLY, TERMINAL BOARD	
1	1 A4076	ASSEMBLY, TERMINAL BOARD	

REQ'D.	ITEM	PART NUMBER	DESCRIPTION	SYMBOL
B N P LIST OF MATERIAL				
MATERIAL		THE TECHNICAL MATERIEL CORP. MAMARONECK, NEW YORK		
FINISH		TITLE ASSEMBLY, LINE FILTER, AP		
UNLESS OTHERWISE SPECIFIED DIMENSIONS ARE IN INCHES AND INCLUDE CHEMICALLY APPLIED OR PLATED FINISHES		DRAWN <i>BN</i>	DATE <i>4-11-69</i>	FINAL APPROVAL <i>[Signature]</i>
DECIMALS .X ± .05 .XX ± .01 .XXX ± .005		CHECKED <i>[Signature]</i>	DATE <i>4-11-69</i>	DATE <i>4-11-69</i>
FRACTIONS ± 1/64 ANGLES ± 0° 30'		ELECT. DES. <i>[Signature]</i>	DATE <i>4-11-69</i>	DATE <i>4-11-69</i>
TOLERANCES		MECH. DES. <i>[Signature]</i>	DATE <i>4-11-69</i>	DATE <i>4-11-69</i>
			SHEET	REV. LTR.

1	RAK208	A4083
QTY./UNIT	MODEL USED ON	ASSY. NO.
SCALE	CODE	

THE CONTENTS OF THIS DRAWING ARE THE EXCLUSIVE PROPERTY OF THE TECHNICAL MATERIEL CORP. ITS UNAUTHORIZED USE OR REPRODUCTION IN WHOLE OR IN PART IS STRICTLY FORBIDDEN.

NOTES

A4078