

IF IT IS FOUND DESIRABLE TO CHANGE ANY TOLERANCE OR OTHER DETAIL SPECIFIED ON THIS DRAWING NOTIFY THE PURCHASER PROMPTLY.

MAXIMUM ALLOWABLE TOLERANCES HAVE BEEN DETERMINED AND DEVIATIONS WILL BE CAUSE FOR REJECTION. REMOVE ALL BURRS AND SHARP EDGES

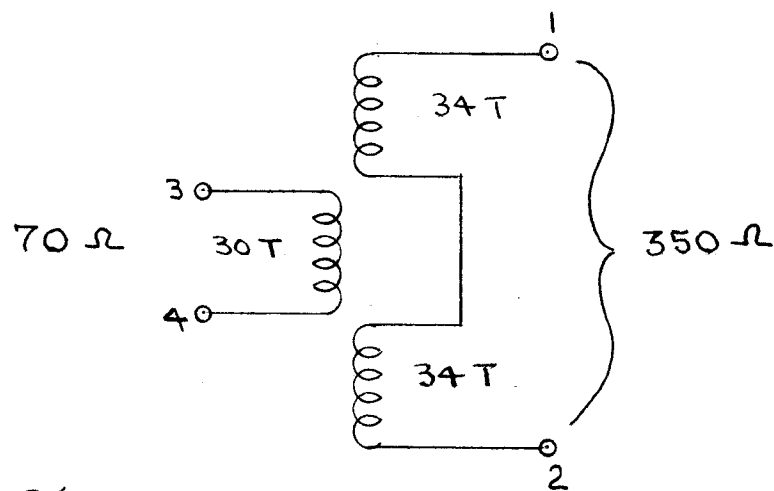
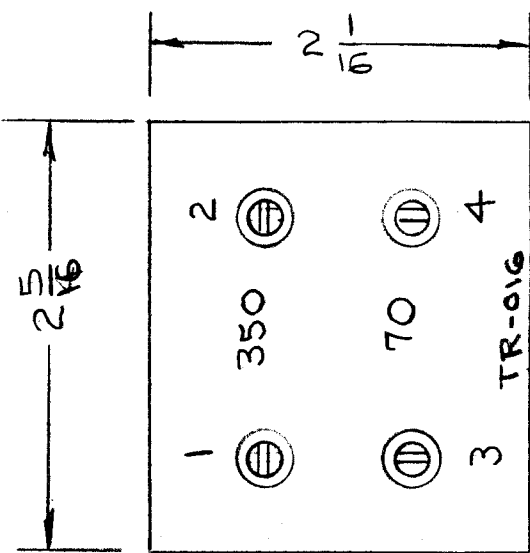

A-485 B

STAMPING:
METAL STAMP BEFORE PAINTING.
1/8 HIGH BLACK GOTHIC AFTER PAINTING.

FINISH:
S-114 ZINC CHROMATE PRIMER.
S-115 SMOOTH GREY ENAMEL

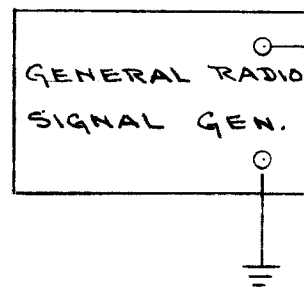

f KC	R.F. VOLTS		
	V1	V2	V3
20	1	.5	1.05
65	1	.53	1.1
200	1	.58	1.05

HEWLETT PACKARD VTVM

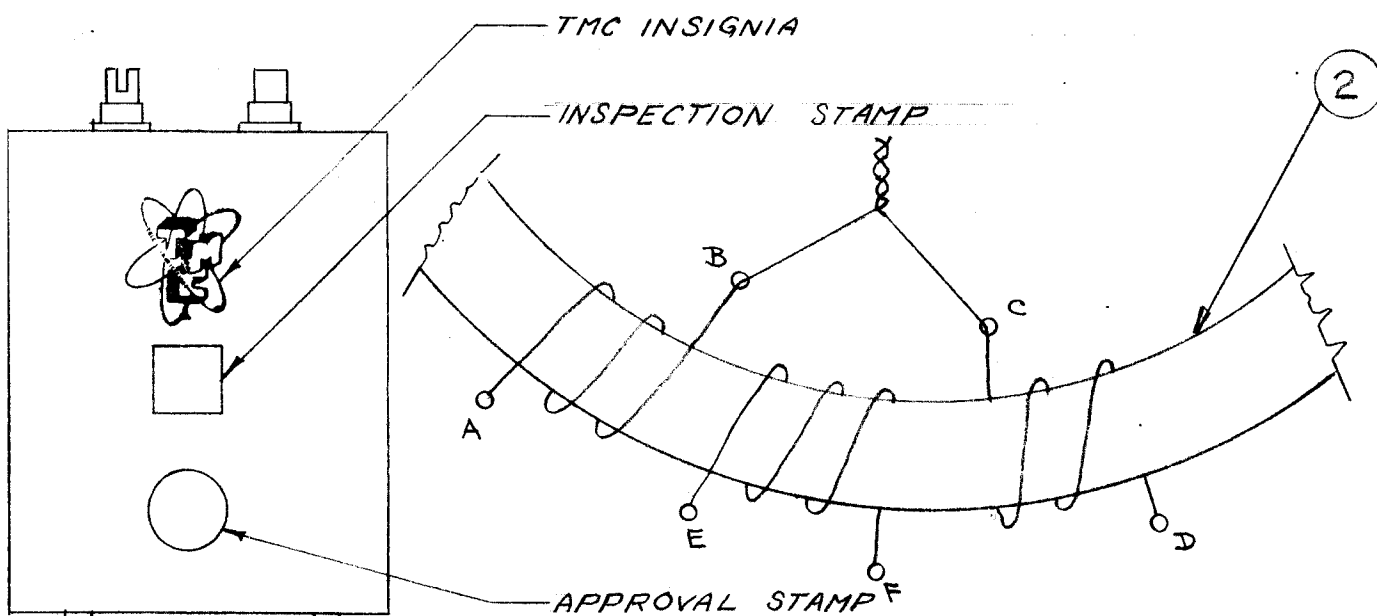

NOT TO BE RELEASED W/O AUTHORIZATION

AUTH. BY.....
DATE:.....

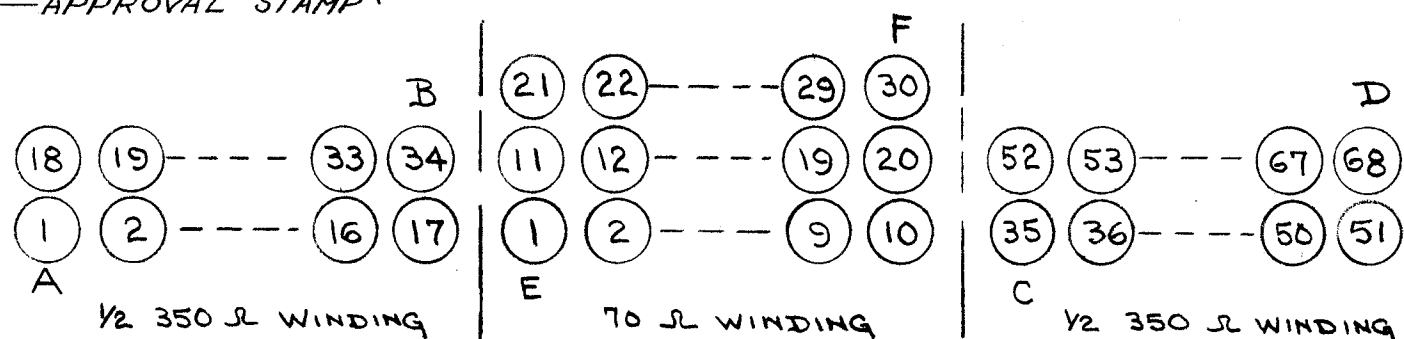

REQ.	ITEM	PART NO.	DESCRIPTION	SYMBOL
1	6	NP-117	TMC INSIGNIA	
X	5	GL-100	POTTING COMPOUND	
X	4	BS-100	SOLDER, SOFT	
X	3	WI-102-9	WIRE	
1	2	CI-104	CORE	
1	1	BX-106	CASE	

ISSUE	ITEM	CHANGED FROM	DATE	CN. NO.	DRAFTS	CHECKER	ENG. APP.
B	1	FINISH ADDED	5/12/53	2	JAD	CWS	WDC
A	1	REDRAWN	7/14/53	1	JAD	CWS	WDC

TOLERANCES: ALL OTHERS DEC. DIM. ±, FRAC. DIM. ±, ANGULAR DIM. ±

SCALE: DRILL, PUNCH, COMMERCIAL STOCK SIZES AND MANUFACTURERS TOLERANCES ARE NOT INCLUDED.

TR-016	PROJECT NO.	ASS'Y. NO.	7-14-53
MODEL	PROJECT NO.	ASS'Y. NO.	DATE

USED ON

THE TECHNICAL MATERIEL CORP. MAMARONECK, NEW YORK		
TR-016		
20-200 KC		
STOCK SIZE		
MATERIAL	WEIGHT PER PC.	
TYPE & TEMPER	JAD 7/13/53	ARB
HEAT TREAT. SPEC.	DRAWN	ELEC. DES. APP.
SEE NOTE	CHECKED	MECH. DES. APP.
FINISH & SPEC. NO.	FINAL APPROVAL	
	A-485	