

HOLE LEGEND		
HOLE	DESCRIPTION	REQ'D
A	1/64 DIA	2
B	3/32 (.0937) DR	6

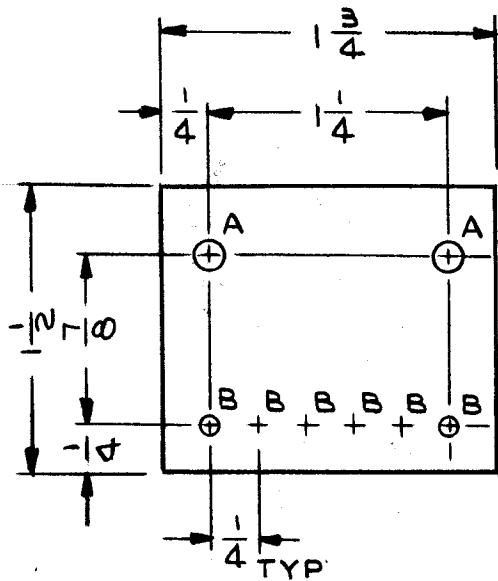

MATERIAL:
EPOXY GLASS LAMINATE
3/32 THK, GRADE G-11

MACHINING (A3982-1)

~ UNLESS OTHERWISE SPECIFIED ~

- 1- MARKING PROCESS : AS PER TMC SPEC. 5727.
- 2- LETTERING : 1/8 HIGH WHITE GOTHIC LOCATED AS SHOWN.
- 3- MARK TMC PT. NO. & LATEST REV. LETTER.

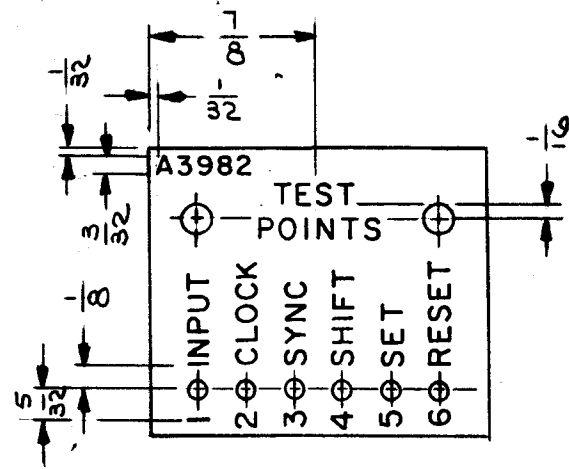

LETTERING (A3982-2)

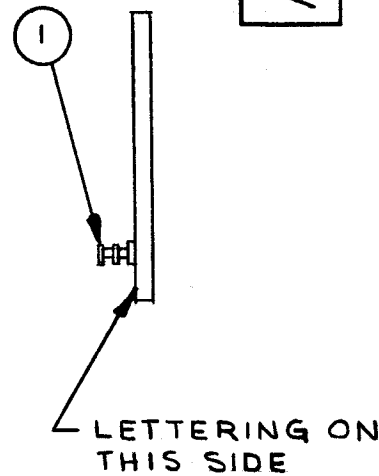

SUB-ASS'Y (A3982-3)

A3982

REVISIONS						
SYM	DESCRIPTION	DATE	E.M.N. NO.	DRAFT	CHKD	APPD
X	EXP. RELEASE	11/6/64		JL	J.M.	
Ø	ORIGINAL RELEASE FOR PRODUCTION	2/10/65	Ø	JL	JCB	

6	1	TE127-5	TERMINAL, STUD	B
REQ'D.	ITEM	PART NUMBER	DESCRIPTION	SYMBOL

F. E. EATON		LIST OF MATERIAL		
MATERIAL	—//—	THE TECHNICAL MATERIEL CORP. MAMARONECK, NEW YORK		
FINISH	—//—	TITLE TERMINAL BOARD ASSY		

1	RTIA-1	A4058
Q'TY./UNIT	MODEL USED ON	ASS'Y. NO.
SCALE 1:1	CODE A	
THE CONTENTS OF THIS DRAWING ARE THE EXCLUSIVE PROPERTY OF THE TECHNICAL MATERIEL CORP. ITS UNAUTHORIZED USE OR REPRODUCTION IN WHOLE OR IN PART IS STRICTLY FORBIDDEN.		

UNLESS OTHERWISE SPECIFIED DIMENSIONS ARE IN INCHES AND INCLUDE CHEMICALLY APPLIED OR PLATED FINISHES		DRAWN J. LESHINSKI	DATE 11/6/64	FINAL APPROVAL	DATE
DECIMALS .X ± .05 .XX ± .01 .XXX ± .005	TOLERANCES	CHECKED JM	DATE 2/9/65	A3982	Ø
FRACTIONS ± 1/64 ANGLES ± 0° 30'		ELECT. DES. W. JORDAN	DATE 2/8/65		
		MECH. DES. W. JORDAN	DATE 2/8/65	SHEET	REV. LTR.

NOTES