

USED ON
ASSY. NO. DATE
9-9-63
9-9-63

REQ. PER UNIT	MODEL	DATE
2	TER-25K/600B	9-9-63
2	TER-18K/600Bf	9-9-63

A-3980 B

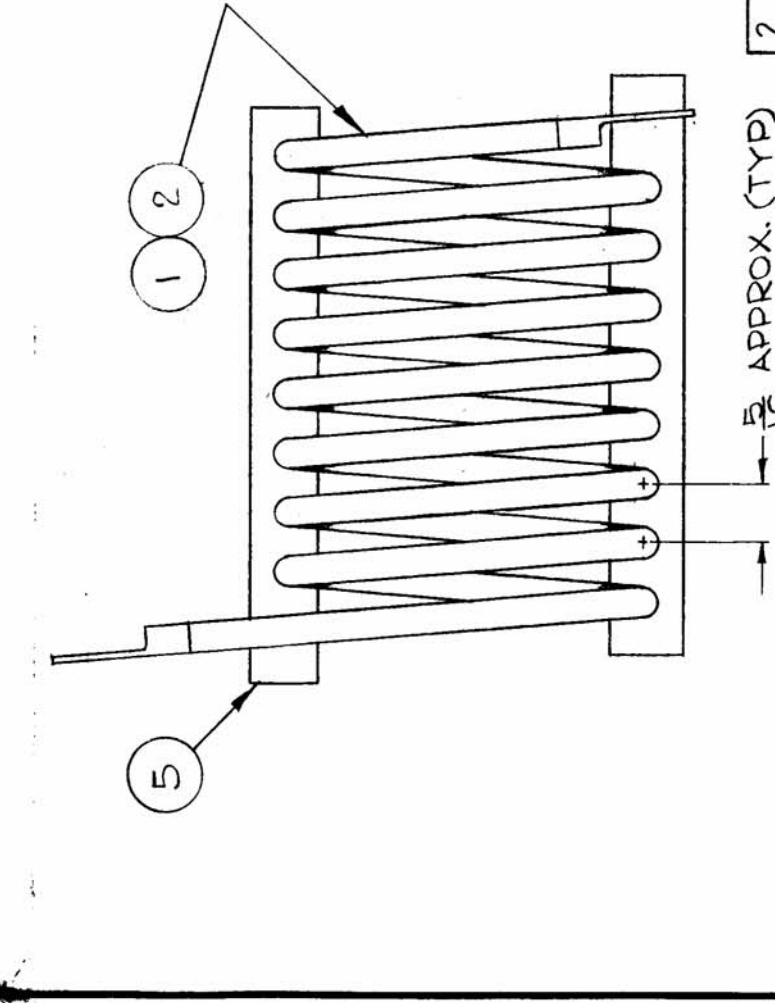
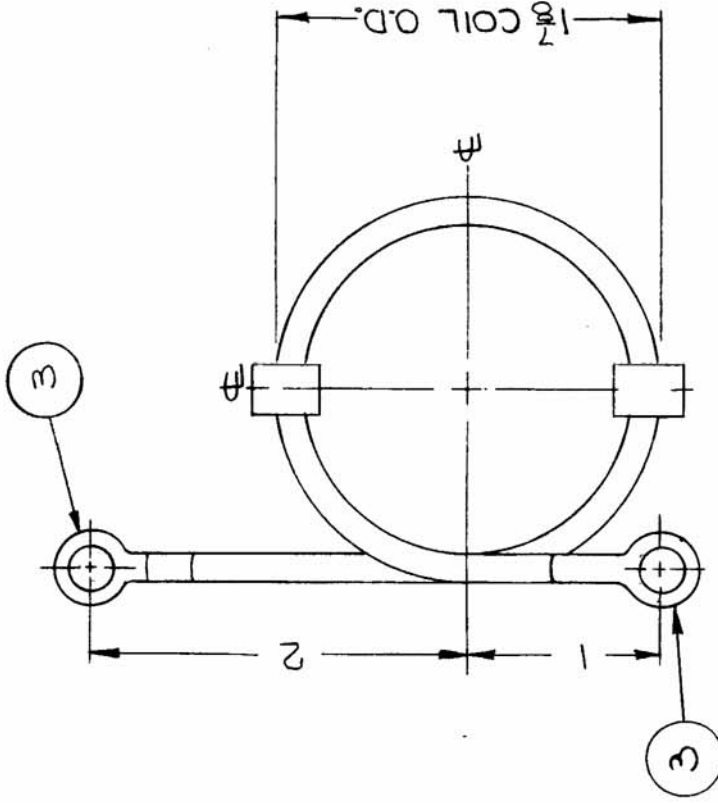

NOTES:
 9 TURNS WOUND ON 1/2 DIA. FORM
 FINISH: SILVER PLATE .0003 THK
 * LENGTHS APPROX:

2	5	PX 776	SPACER, COIL	SYMBOL
X	4	BS-100	SOLDER, TIN ALLOY	
2	3	TE-141-3	TERMINAL, LUG #10	
45"	2	PX-370-9-7	INSULATION, SLEEVING, TEFLON	
46"	1	TU-100-ZN	TUBING, COPPER, SOFT	
REQ. ITEM		PART NO.	DESCRIPTION	
			THE TECHNICAL MATERIEL CORP. MAMARONECK, NEW YORK	
			COIL ASSEMBLY	
			STOCK SIZE	
			MATERIAL	
			TYPE & TEMPER	
			HEAT TREAT. SPEC.	
			DRAWN	
			CHECKED	
			ELEC. DES. APP.	
			MECH. DES. APP.	
			FINISH & SPEC. NO.	
			FINAL APPROVAL	
			A-3980 B	