

REQ. PER UNIT	USED ON	MODEL	DATE
1	ASSY. NO.	CHG-2A	4-9-64
		A 3595 A	

.094 ± .097 DIA.  
DRILL THRU

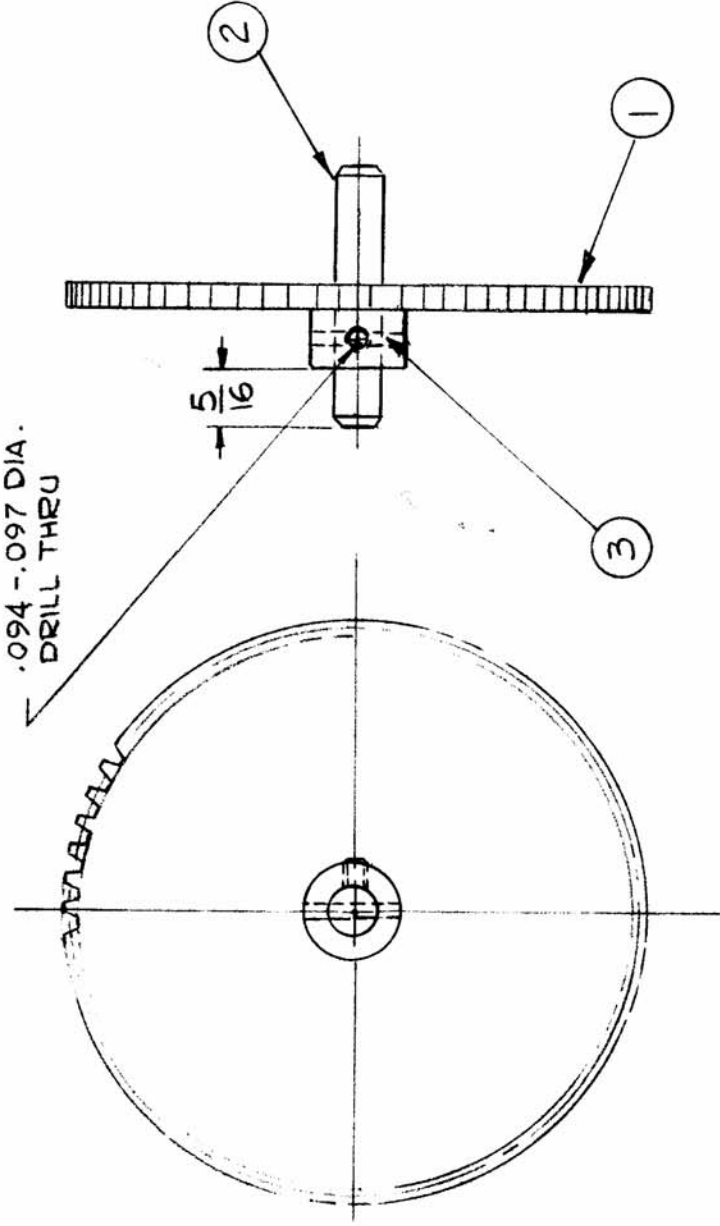

REQ. ITEM	PART NO.	DESCRIPTION	SYMBOL
1	PN 52-094-8	PIN, ROLL	
1	PM 691RF 1,375B	SHAFT	
1	GR-202	GEAR, IDLER	
		KRUY	
		THE TECHNICAL MATERIEL CORP. MAMARONECK. NEW YORK	
		GEAR, IDLER, ASSY	
		G.D.L	
		CHECKED	11/16/65
		DRAWN	FINAL APPROVAL
		TYPE & TEMPER	
		HEAT TREAT. SPEC.	
		MATERIAL	
		FINISH & SPEC. NO.	A 3595 A
		ELEC. DES. APP.	
		MECH. DES. APP.	

DATE	2-1-67	17763	WFO	G.D.L	11-15-65	11-15-65	11-15-65
SCALE	1 : 1						
DESCRIPTION	ITEM 3 WAS PN 114-4						
UNLESS OTHERWISE SPECIFIED	DIMENSIONS ARE IN INCHES AND INCLUDE						
CHEMICALLY APPLIED OR PLATED FINISHES	FRACTIONS						
DECIMALS	± 1/64						
.XX ± .01	ANGLES						
.XXX ± .005	± 0° 30'						
TOLERANCES							