

A 3507 Ø

REVISIONS

SYM	DESCRIPTION	DATE	E.M.N. NO.	DRAFT	CHKD	APPD
Ø	ORIGINAL RELEASE FOR PRODUCTION	6-10-65	—	JC		

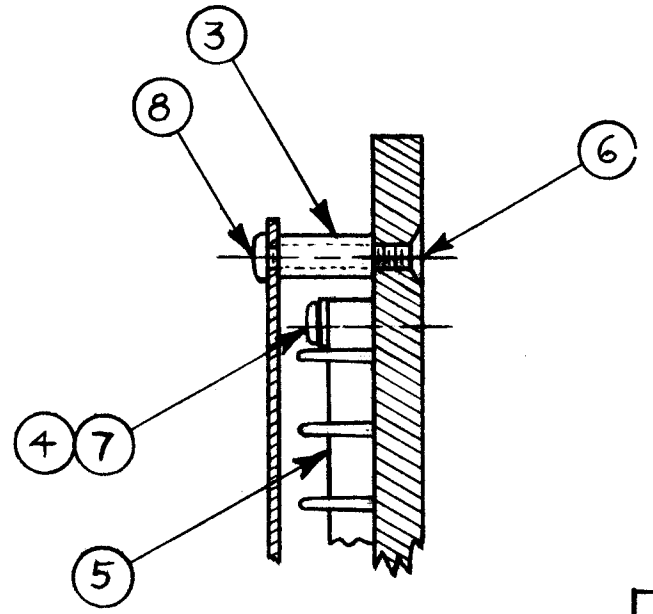
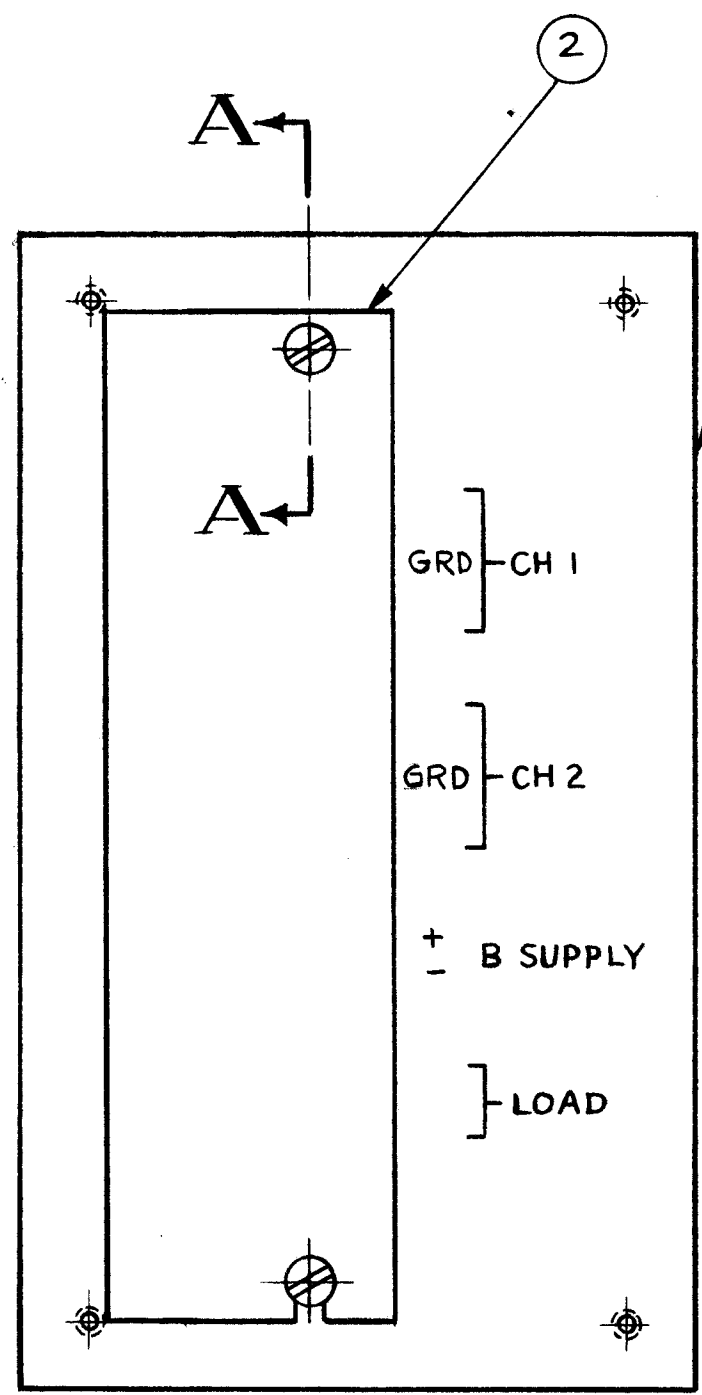

SECTION AA

REQ'D.	ITEM	PART NUMBER	DESCRIPTION	SYMBOL
2	8	SCBP0632BN5	SCREW, MACHINE, BINDING HD	
4	7	SCBP0440BN8	SCREW, MACHINE, BINDING HD	
2	6	SCFP0632BN8	SCREW, MACHINE, FLAT HD	
1	5	TM 102-10	TERMINAL STRIP, BARRIER TYP.	
2	4	MS 154-1	STRADDLE PLATE	
2	3	TE 135-3	STAND-OFF, SPACER	
1	2	PX 840	COVER, SHIELD, TERMINAL	
1	1	LD 1474/PX 839	MARKING, BOARD, TERMINAL	

1. JOHNSON LIST OF MATERIAL

MATERIAL	THE TECHNICAL MATERIEL CORP. MAMARONECK, NEW YORK		
FINISH	TITLE TERMINAL BLOCK, ASSY		

1	RAK-31B	
Q'TY./UNIT	MODEL USED ON	ASS'Y. NO.
SCALE 1:1	CODE	
THE CONTENTS OF THIS DRAWING ARE THE EXCLUSIVE PROPERTY OF THE TECHNICAL MATERIEL CORP. ITS UNAUTHORIZED USE OR REPRODUCTION IN WHOLE OR IN PART IS STRICTLY FORBIDDEN.		

UNLESS OTHERWISE SPECIFIED DIMENSIONS ARE IN INCHES AND INCLUDE CHEMICALLY APPLIED OR PLATED FINISHES		DRAWN <i>N. Peters</i>	DATE 2-26-64	FINAL APPROVAL <i>M. H. King</i>	DATE 6/14/65
DECIMALS .X ± .05 .XX ± .01 .XXX ± .005	TOLERANCES	CHECKED <i>[Signature]</i>	DATE 6-10-65	A 3507 Ø	
FRACTIONS ± 1/64 ANGLES ± 0° 30'		ELECT. DES. <i>[Signature]</i>	DATE	SHEET	
		MECH. DES. <i>[Signature]</i>	DATE	REV. LTR.	

NOTES