

B  
A 3489

REVISIONS

SYM	DESCRIPTION	DATE	E.M.N. NO.	DRAFT	CHKD	APPD
X	EXPERIMENTAL RELEASE	3-6-64				
Ø	ORIGINAL RELEASE FOR PRODUCTION	8-14-64				
A	PICTORIAL REVISED (ITEM 3) ITEM 4 WAS PN 59-062-6	11/3/64	12851			
B	ADDED IT. 5 & CALLOUTS, ADD REF. TO .12	9-26-66	16886	RME		

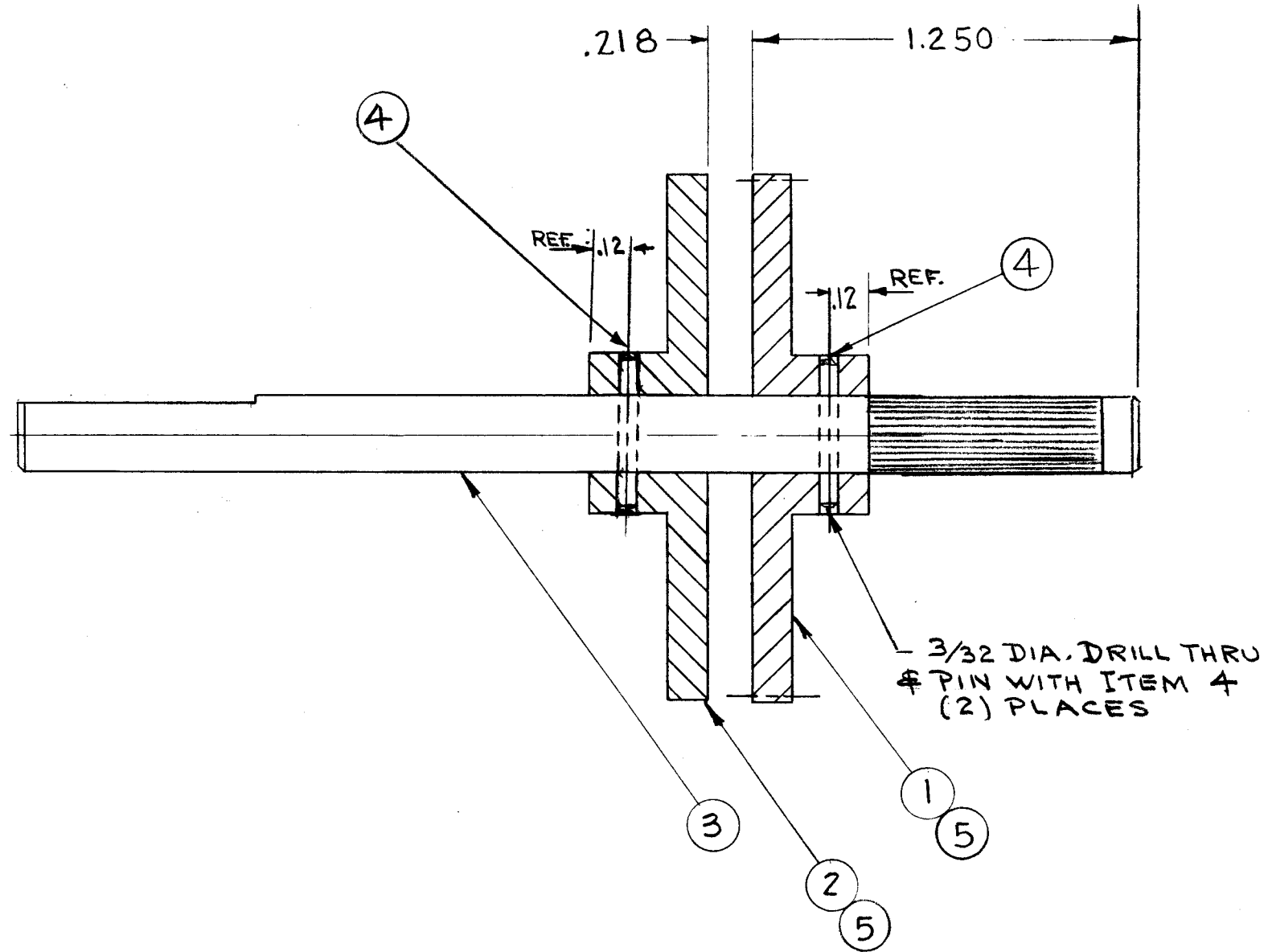

REQ'D.	ITEM	PART NUMBER	DESCRIPTION	SYMBOL
2	5	SLHC0632SS3	SET SCREW	
2	4	PN114-4	PIN, GROOVED	
1	3	GR 203	GEAR, SHAFT, PINION	
1	2	PM 1029	DETENT	
1	1	GR 205-2	GEAR, SPUR, HUB	

T. KRUY LIST OF MATERIAL

MATERIAL	THE TECHNICAL MATERIEL CORP. MAMARONECK, NEW YORK		
FINISH	TITLE GEAR ASSY (TURRET)		
UNLESS OTHERWISE SPECIFIED DIMENSIONS ARE IN INCHES AND INCLUDE CHEMICALLY APPLIED OR PLATED FINISHES	DRAWN <i>Kruey</i>	DATE 2-11-64	FINAL APPROVAL <i>RAC</i>
	CHECKED <i>@</i>	DATE 3-3-64	
DECIMALS .X ± .05 .XX ± .01 .XXX ± .005	TOLERANCES	FRACTIONS ± 1/64 ANGLES ± 0° 30'	DATE 8-14-64
ELECT. DES.		DATE	A 3489
MECH. DES. <i>T. Kruey</i>		DATE	B
SHEET			REV. LTR.

1	HFR-2	A3533
1	HFR-2	A3548
Q'TY./UNIT	MODEL USED ON	ASS'Y. NO.
SCALE 2:1	CODE A	
THE CONTENTS OF THIS DRAWING ARE THE EXCLUSIVE PROPERTY OF THE TECHNICAL MATERIEL CORP. ITS UNAUTHORIZED USE OR REPRODUCTION IN WHOLE OR IN PART IS STRICTLY FORBIDDEN.		

NOTES