

REVISIONS

SYM	DESCRIPTION	DATE	E.M.N. NO.	DRAFT	CHKD	APPD
X1	ITEMS 1, 2, 3 ADDED	4/25/64	1	FF		
X2	REVISED NOTES 2 & 3; ITEM 3 WAS WI-141-34-5Z GRN/RD.	4/10/64		JL		
O	ORIGINAL RELEASE FOR PRODUCTION	6-1-64	O	A.M.	@	
A	IT. 1 WAS CL-127-4, STEP 1 - NOTES 1 & 2 CORRECTED STEP-1 NOTE 2 WAS NOTE 3, NOTE 3 WAS NOTE 2	8-8-64	12033	WB	HP	

A-3450

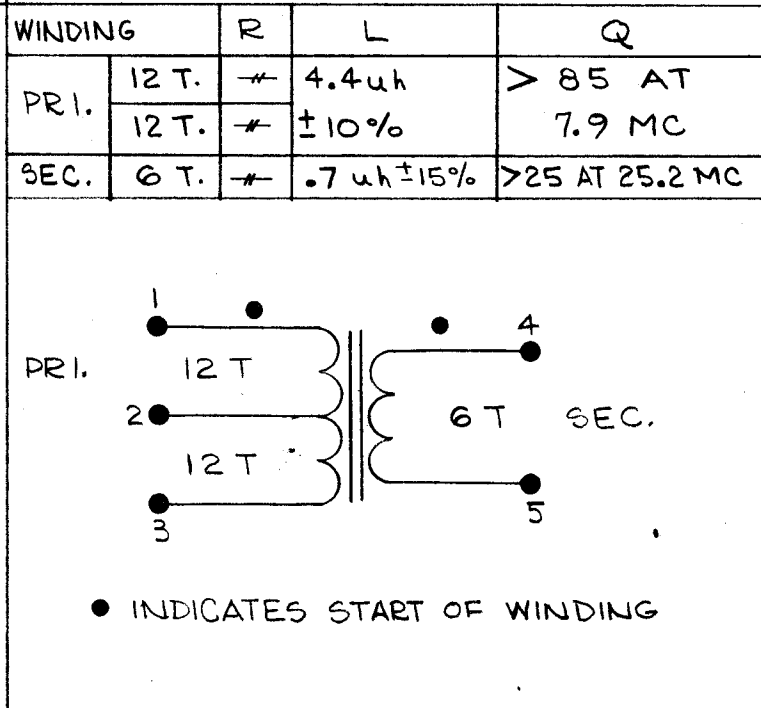
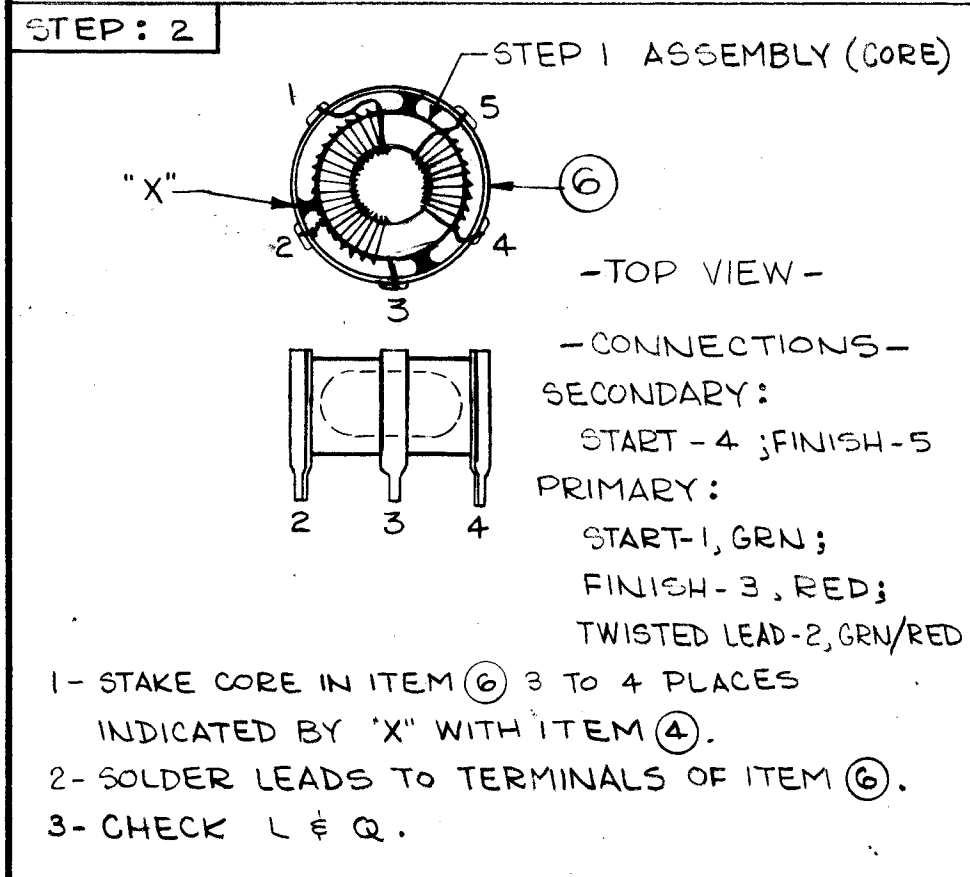

REQ'D.	ITEM	PART NUMBER	DESCRIPTION	SYMBOL
X	8	BS-100	SOLDER, SOFT	
X	7	GL-128-2	COMPOUND, POTTING (RED)	
1	6	TM-124-2	TERMINAL, COLLAR	
X	5	GL-130	CEMENT, "Q" DOPE	
X	4	GL-103	DUCO, CEMENT	
X	3	WI-141-34-2	WIRE, MAGNET (RED)	
X	2	WI-141-34-5	WIRE, MAGNET (GREEN)	
1	1	CI-127-4	CORE	

M. GELLMAN LIST OF MATERIAL

THE TECHNICAL MATERIEL CORP.
MAMARONECK, NEW YORK

TZ-167 ASSEMBLY

UNLESS OTHERWISE SPECIFIED DIMENSIONS ARE IN INCHES AND INCLUDE CHEMICALLY APPLIED OR PLATED FINISHES	DRAWN	DATE	FINAL APPROVAL	DATE
DECIMALS .X ± .05 .XX ± .01 .XXX ± .005	<i>[Signature]</i>	8-30-63	<i>[Signature]</i>	
FRACTIONS ± 1/64 ANGLES ± 0° 30'	CHECKED	DATE 5-7-64		
TOLERANCES	ELECT. DES.	DATE 6-1-64	A-3450	A
	MECH. DES.	DATE	SHEET	REV. LTR.

NOTES

Q'TY./UNIT	MODEL USED ON	ASS'Y. NO.
10	LFS-1	
SCALE	CODE	
//	A	

THE CONTENTS OF THIS DRAWING ARE THE EXCLUSIVE PROPERTY OF THE TECHNICAL MATERIEL CORP. ITS UNAUTHORIZED USE OR REPRODUCTION IN WHOLE OR IN PART IS STRICTLY FORBIDDEN.