

USED ON
 MODEL AX-395 DATE 10-3-63
 REQ. PER UNIT 2

A-3261 A

37 TURNS OF ITEM NO. 6

CLOSE WOUND

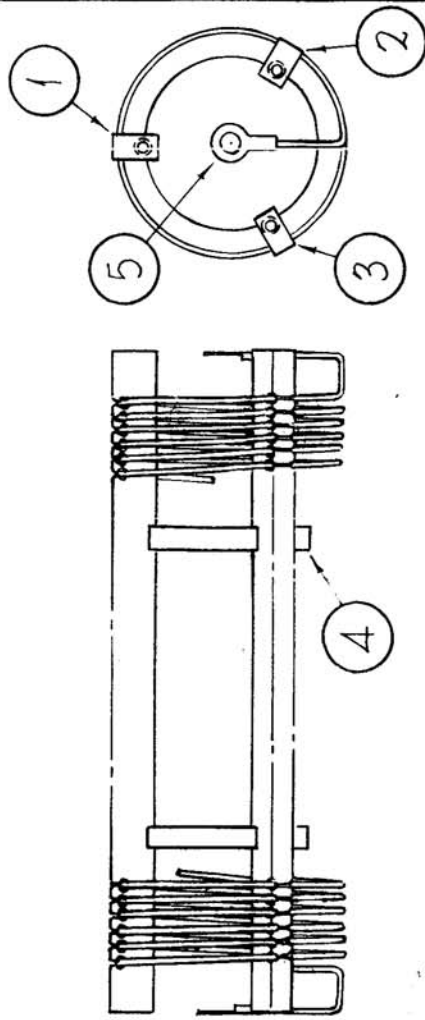
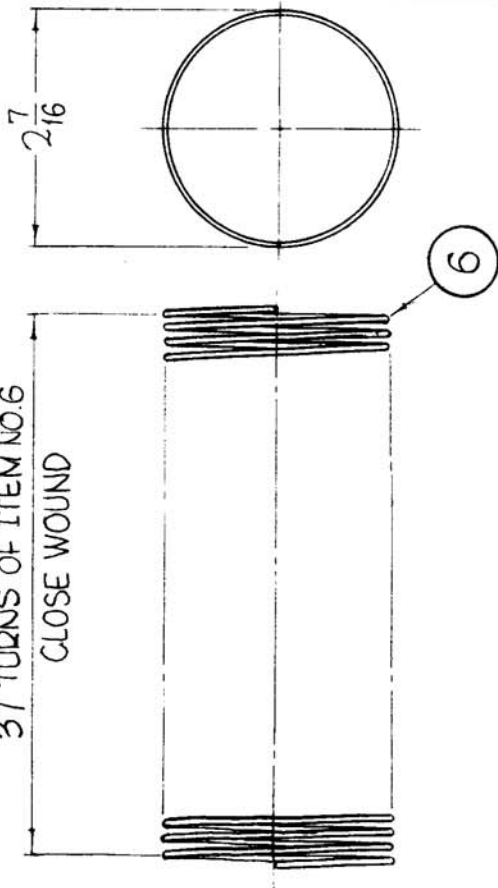

REQ. ITEM	PART NO.	DESCRIPTION	SYMBOL
X 6	WI-139-1	WIRE, ELECTRICAL	
2 5	TE-159-32961	LUG, SOLDERLESS	
2 4	PX-720	SPACER, COIL	
1 3	PX-721-3	SUPPORT, COIL	
1 2	PX-721-2	SUPPORT, COIL	
1 1	PX-721-1	SUPPORT, COIL	

REQ. ITEM	PART NO.	DESCRIPTION	SYMBOL
		F. BUDETTI	
THE TECHNICAL MATERIEL CORP. MAMARONECK, NEW YORK			
ASSY. COIL			
TYPE & TEMPER		HEAT TREAT. SPEC.	CHECKED
FINISH & SPEC. NO.			FINAL APPROVAL
MATERIAL			
DRAWN			
ELEC. DES. APP.			
MECH. DES. APP.			

SYM	DESCRIPTION	DATE	CH. NO.	DRAFTS	CHECKER	ENG. APP.
A	IT.5 WAS TE-156-32961	9.2.64	12257	ATB	ATB	AS
O	ORIGINAL RELEASE	5.18.64		ATB		
X1	NO OF TURNS WAS 59	1-6-64				

UNLESS OTHERWISE SPECIFIED
 DIMENSIONS ARE IN INCHES AND INCLUDE
 CHEMICALLY APPLIED OR PLATED FINISHES

SCALE 1/2" = 1"

DECIMALS
 .X ± .05
 .XX ± .01
 .XXX ± .005

FRACTIONS
 ± 1/64
 ANGLES
 ± 0° 30'

TOLERANCES

CODE