

IF IT IS FOUND DESIRABLE TO CHANGE ANY TOLERANCE OR OTHER DETAIL SPECIFIED ON THIS DRAWING NOTIFY THE PURCHASER PROMPTLY.

MAXIMUM ALLOWABLE TOLERANCES HAVE BEEN DETERMINED AND DEVIATIONS WILL BE CAUSE FOR REJECTION. REMOVE ALL BURRS AND SHARP EDGES

A-336 A

NOTE:  
FIXED GEAR SHALL BE SOLDERED TO HUB.  
FREE GEAR SHALL MOVE FREELY WITHOUT SIDE WOBBLE.  
CONDENSER MUST BE ASSEMBLED SO THAT THIS SPLIT GEAR HAS A SNAP ACTION WHEN TWISTED AND THEN FREED.

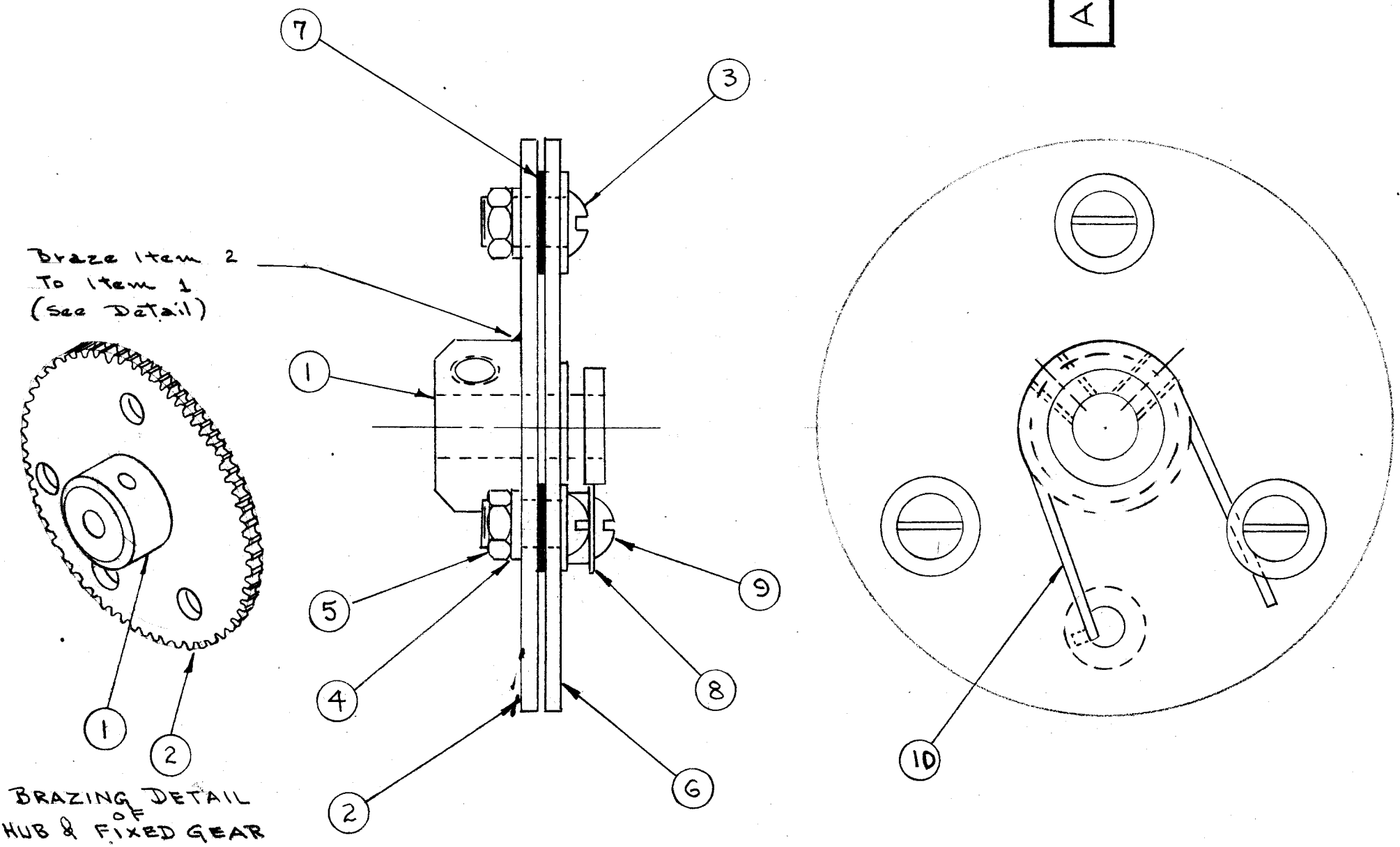

| REQ. | ITEM | PART NO.    | DESCRIPTION    | SYMBOL |
|------|------|-------------|----------------|--------|
| 1    | 10   | SP-100      | SPRING         |        |
| 1    | 9    | SCRS0632SN6 | SCREW, MACHINE |        |
| 4    | 8    | PM-183      | SPACER         |        |
| 3    | 7    | WA-108      | WASHER         |        |
| 1    | 6    | GR-110      | FREE GEAR      |        |
| 3    | 5    | NTH0632SN8  | NUT, HEX       |        |
| 3    | 4    | LWS06MRC    | WASHER, LOCK   |        |
| 2    | 3    | SCRS0632SN5 | SCREW, MACHINE |        |
| 1    | 2    | GR-111      | FIXED GEAR     |        |
| 1    | 1    | PM-182      | HUB            |        |

|  |                |            |
|--|----------------|------------|
| THE TECHNICAL MATERIEL CORP.<br>MAMARONECK, NEW YORK |                |            |
| SPLIT SPUR GEAR<br>ASSEMBLY                          |                |            |
| DATE   | DRAWN          | MECH. DES. |
| 1-27-53  | CDD            | UD         |
| CHECKED  | FINAL APPROVAL |            |
| ASST   |                |            |
| SUPERCEDES<br>AMS-227                                |                | A-336 A    |

| A          | 1   | BRAZING DETAIL ADDED  | 12/9/53   | 1       | ADD     | C.S.E.  | UD        |
|------------|---|---|-----------|---------|---------|---------|-----------|
| ISSUE      | ITEM  | CHANGED FROM  | DATE      | CN. NO. | DRAFTS  | CHECKER | ENG. APP. |
| TOLERANCES |   | SCALE: $\frac{1}{2}$  |           |         |         |         |           |
| ALL OTHERS | DEC. DIM. $\pm$<br>FRAC. DIM. $\pm$<br>ANGULAR DIM. $\pm$ | DRILL, PUNCH, COMMERCIAL STOCK SIZES AND MANUFACTURERS TOLERANCES ARE NOT INCLUDED. |           |         |         |         |           |
| UNIT QTY   | MODEL   | PROJECT NO.   | APPY. NO. | DATE    | USED ON |         |           |
| 1          | A-1000  | 101   | A-1000    | 1-27-53 |         |         |           |