

REVISIONS							
ZONE	SYM	DESCRIPTION	DATE	E.M.N. NO.	DRAFT	CHKD	APPD
X1		DWG # WAS A-326	11/14/63				
O		ORIGINAL RELEASE FOR PRODUCTION	5/28/64	0	A.M.		

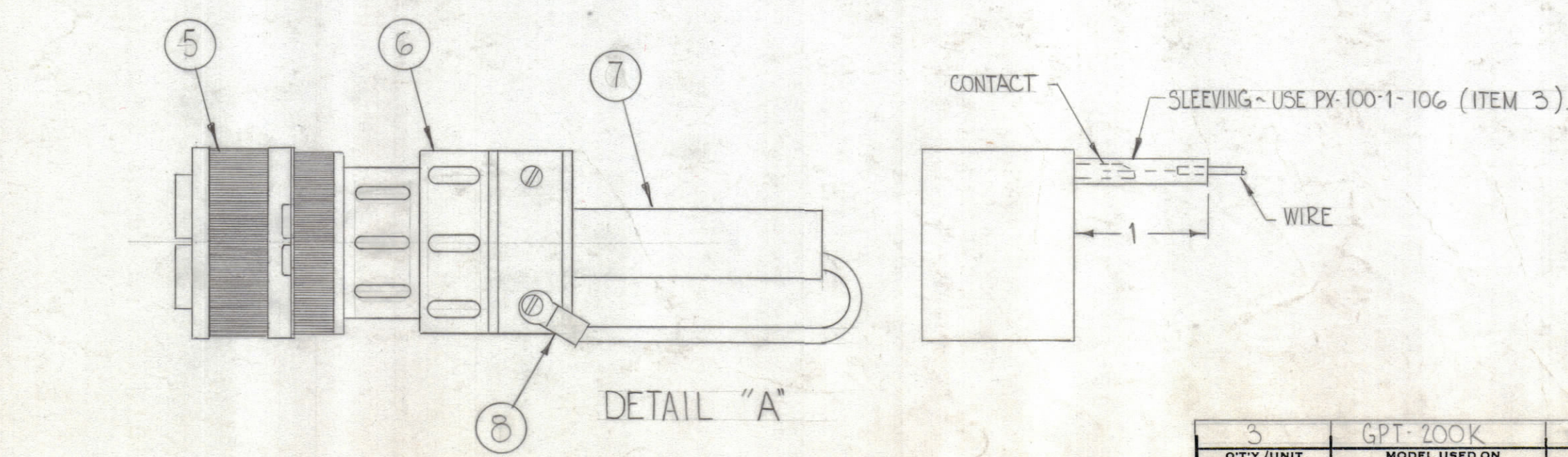
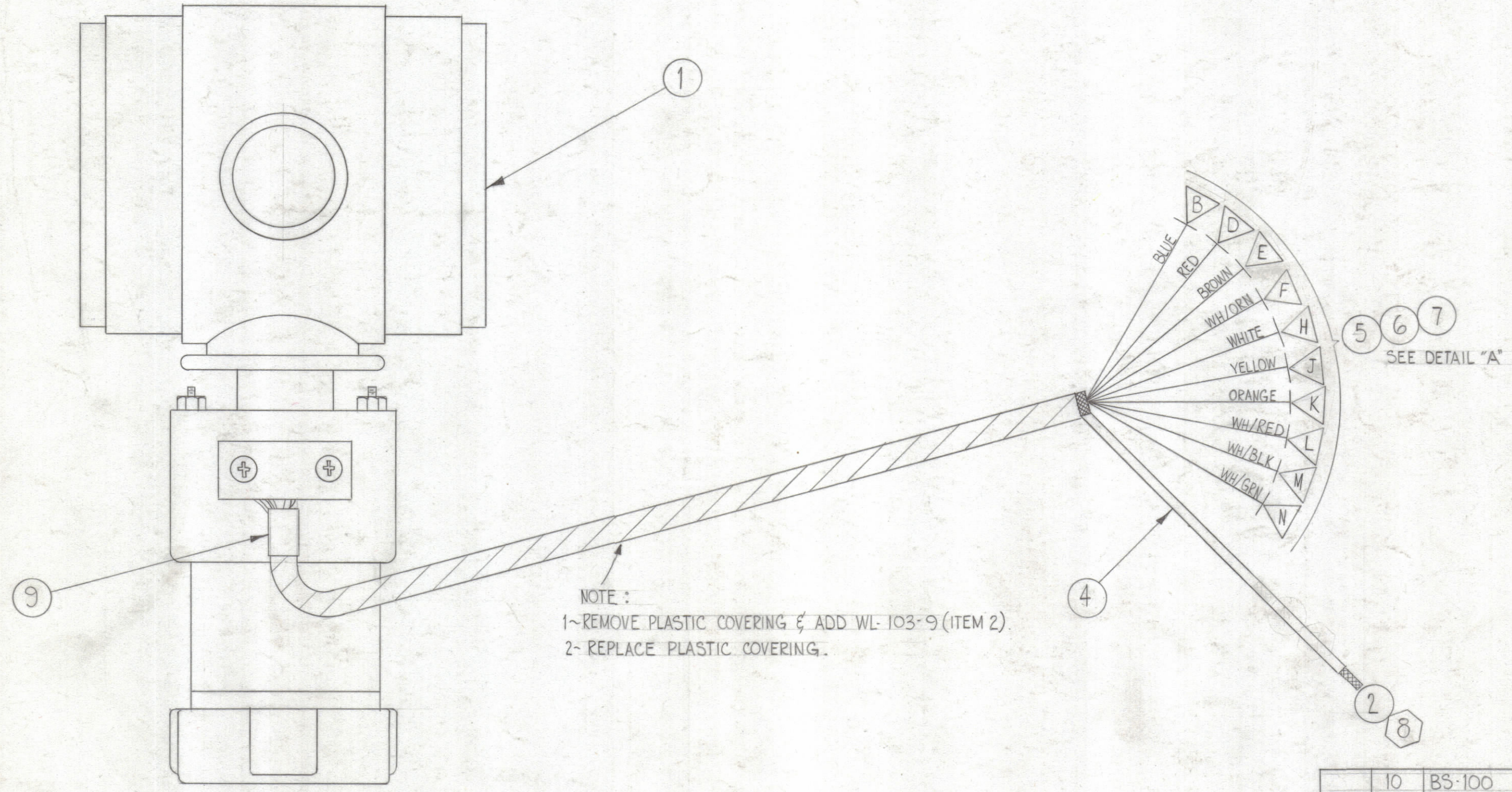

REQ'D.	ITEM	PART NUMBER	DESCRIPTION	SYMBOL
	10	BS-100	SOLDER, SOFT	
	9	TA-102-3	TAPE, ELECTRICAL	
1	8	TE-156-32947	SOLDERLESS, TERMINAL	
1	7	MS3420-12A	BUSHING, CABLE	
1	6	MS3057-12	CLAMP, CABLE	
1	5	MS3106B-20-27P	CONNECTOR, PLUG	
	4	PX-100-1-148	SLEEVING, INSULATION	BLACK
	3	PX-100-1-106	SLEEVING, INSULATION	BLACK
	2	WL-103-9	BRAID, WIRE, FLAT	
1	1	RL-155	RELAY, VACUUM, COAXIAL	

F. BUDETTI LIST OF MATERIAL				
MATERIAL		THE TECHNICAL MATERIEL CORP. MAMARONECK, NEW YORK		
FINISH		TITLE RL-155 ASSY.		
Q'TY./UNIT	MODEL USED ON	ASSY. NO.	DRAWN	DATE
3	GPT-200K	A-2750	W.A. FRANCO	9-27-63
SCALE	CODE		CHECKED	DATE
			<i>W.A.</i>	<i>9/27/63</i>
UNLESS OTHERWISE SPECIFIED DIMENSIONS ARE IN INCHES AND INCLUDE CHEMICALLY APPLIED OR PLATED FINISHES		ELECT. DES.		DATE
DECIMALS X ± .05 .XX ± .01 .XXX ± .005		TOLERANCES		ANGLES ± 1/64 ± 0° 30'
		MECH. DES.		DATE
		<i>W.A.</i>		<i>5/18/64</i>
			FINAL APPROVAL	DATE
			<i>W.A.</i>	<i>5/18/64</i>
			SHEET	REV. LTR.
			A-2751	0

NOTES

THE CONTENTS OF THIS DRAWING ARE THE EXCLUSIVE PROPERTY OF THE TECHNICAL MATERIEL CORP. ITS UNAUTHORIZED USE OR REPRODUCTION IN WHOLE OR IN PART IS STRICTLY FORBIDDEN.

A-2751 0