

A-2387

THE CONTENTS OF THIS DRAWING ARE THE EXCLUSIVE PROPERTY OF THE TECHNICAL MATERIEL CORP. ITS UNAUTHORIZED USE OR REPRODUCTION IN WHOLE OR IN PART IS STRICTLY FORBIDDEN.

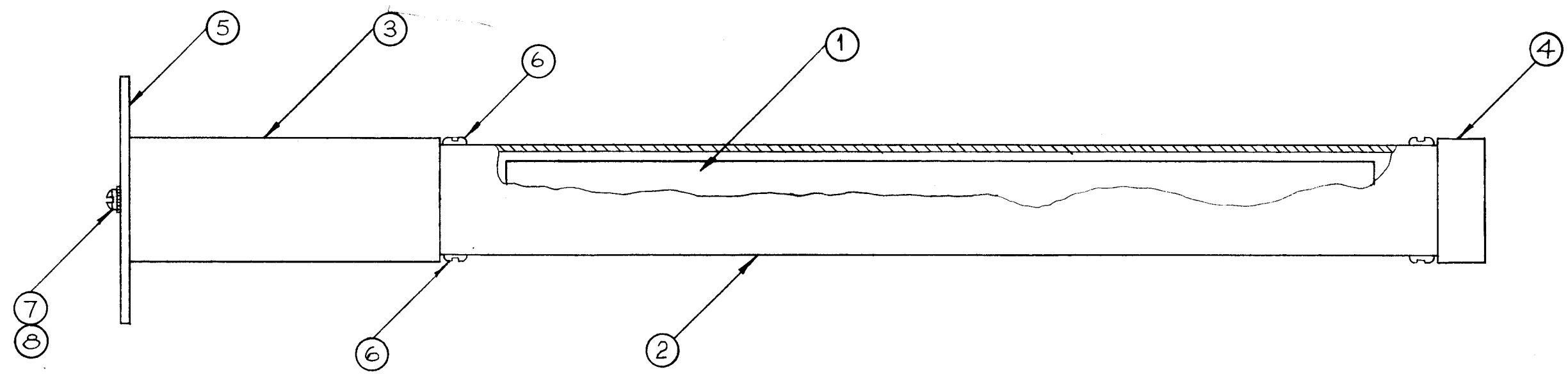

1	8	LWEO6MRN	LOCKWASHER, EXTERNAL TOOTH	
1	7	SCBP0832BN8	SCREW, MACHINE (PHILLIPS)	
4	6	SFB0440SC6	SCREW, THREAD CUTTING SLOTTED HEAD	
1	5	MS-2363	PLATE, FORM MTG.	
1	4	PX-579	CAP, END, CORE FORM	
1	3	PX-580	CAP, END, CORE FORM, LONG	
1	2	PX-578	FORM, CORE	
1	1	CI-112-Q <sub>2</sub> -7-L	CORE, FERRAMIC	
REQ.	ITEM	PART NO.	F. BUDETTI DESCRIPTION	SYMBOL
— ss —			THE TECHNICAL MATERIEL CORP.	
STOCK SIZE			MAMARONECK, NEW YORK	
— ss —			CORE, SUPPORT ASSY.	
MATERIAL				
			G. SENCEN	BP
TYPE & TEMPER			DRAWN	CHECKED
HEAT TREAT. SPEC.				FINAL APPROVAL
— ss —			aa	aa
FINISH & SPEC. NO.			ELEC. DES. APP.	MECH. DES. APP.
			A-2387	

SYM	DESCRIPTION	DATE	CH. NO.	DRAFTS	CHECKER	ENG. APP.
UNLESS OTHERWISE SPECIFIED:		SCALE: DO NOT SCALE				
DIMENSIONS ARE IN INCHES		MAXIMUM ALLOWABLE TOLERANCES HAVE BEEN DETERMINED AND ANY DEVIATIONS WILL BE CAUSE FOR REJECTION.				
TOLERANCES ON FRACTIONS ± 1/64		REMOVE ALL BURRS AND SHARP EDGES				
DECIMALS ± .005						
ANGLES ± 1/2°						
1	KIT-118	4-13-62				
1	GPT-10K	4-13-62			AX-136	
REQ. PER UNIT	MODEL	SECTION	ASS'Y. NO.	DATE	USED ON	