

THE CONTENTS OF THIS DRAWING ARE THE EXCLUSIVE PROPERTY OF THE TECHNICAL MATERIEL CORP. ITS UNAUTHORIZED USE OR REPRODUCTION IN WHOLE OR IN PART IS STRICTLY FORBIDDEN.

A-2357

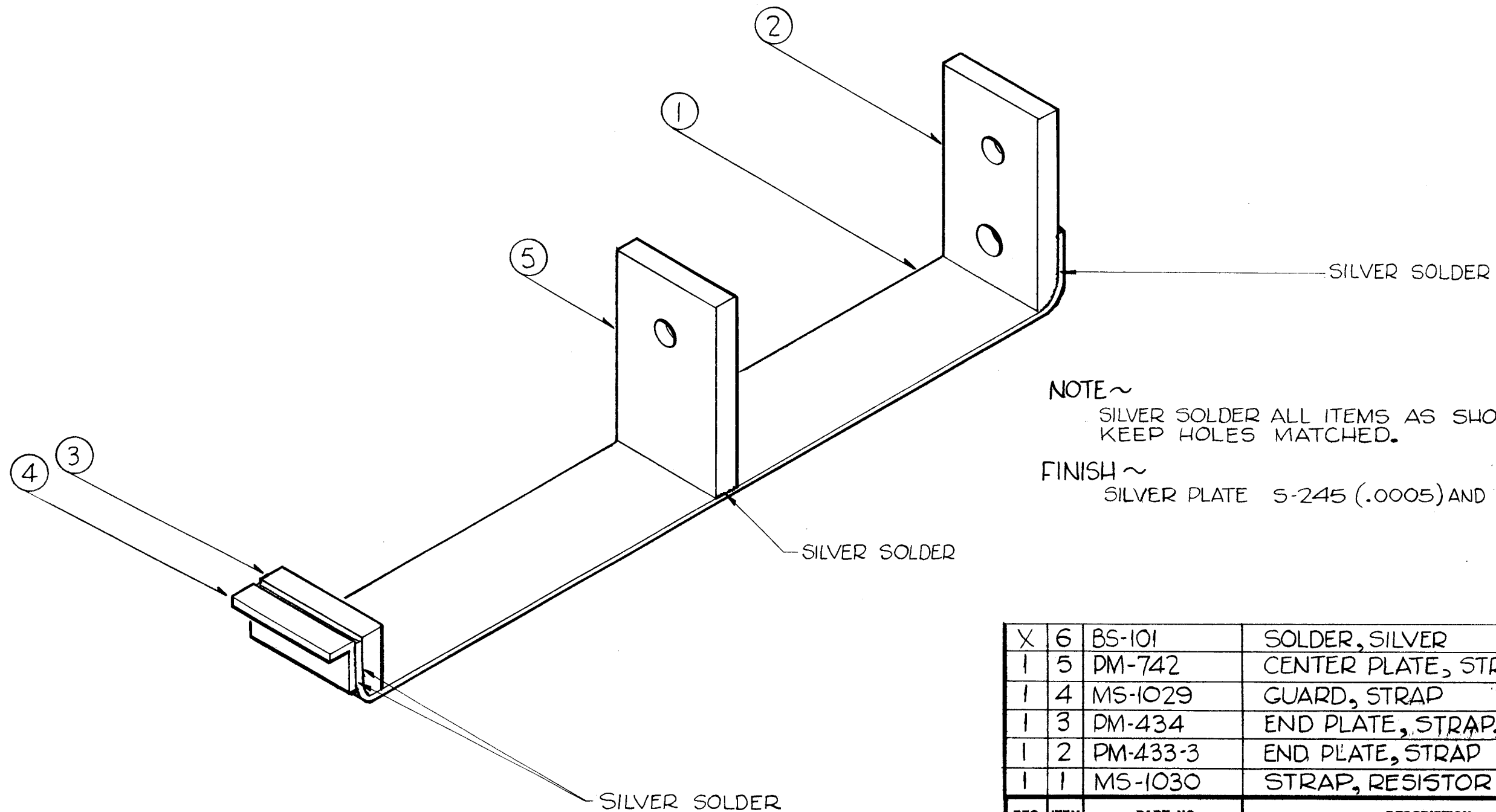

NOTE ~
SILVER SOLDER ALL ITEMS AS SHOWN, KEEP HOLES MATCHED.

FINISH ~
SILVER PLATE S-245 (.0005) AND CLEAR IRIDITE.

X	6	BS-101	SOLDER, SILVER	
1	5	PM-742	CENTER PLATE, STRAP	
1	4	MS-1029	GUARD, STRAP	
1	3	PM-434	END PLATE, STRAP, SMALL	
1	2	PM-433-3	END PLATE, STRAP	
1	1	MS-1030	STRAP, RESISTOR	

REQ.	ITEM	PART NO.	DESCRIPTION	SYMBOL
//			THE TECHNICAL MATERIEL CORP. MAMARONECK, NEW YORK	
//			CENTER, RESISTOR, TOP STRAP ASSEMBLY	
//			TER - 5000 - 50	
//			MATERIAL	
//			DRAWN: <i>D. J. Man</i> RUIZZO CHECKED: <i>OR</i> FINAL APPROVAL: <i>SJM</i>	
//			TYPE & TEMPER HEAT TREAT. SPEC. SEE NOTE ELEC. DES. APP. MECH. DES. APP.	
//			A-2357	

SYM	DESCRIPTION	DATE	CH. NO.	DRAFTS	CHECKER	ENG. APP.
	UNLESS OTHERWISE SPECIFIED: DIMENSIONS ARE IN INCHES TOLERANCES ON FRACTIONS ± 1/64 DECIMALS ± .005 ANGLES ± 1/2°					
	SCALE: <i>A</i> MAXIMUM ALLOWABLE TOLERANCES HAVE BEEN DETERMINED AND ANY DEVIATIONS WILL BE CAUSE FOR REJECTION. REMOVE ALL BURRS AND SHARP EDGES					

REQ. PER UNIT	MODEL	SECTION	ASS'Y. NO.	DATE
1	TER-5000-50			1-30-62
USED ON				