

A-2345

THE CONTENTS OF THIS DRAWING ARE THE EXCLUSIVE PROPERTY OF THE TECHNICAL MATERIEL CORP. ITS UNAUTHORIZED USE OR REPRODUCTION IN WHOLE OR IN PART IS STRICTLY FORBIDDEN.

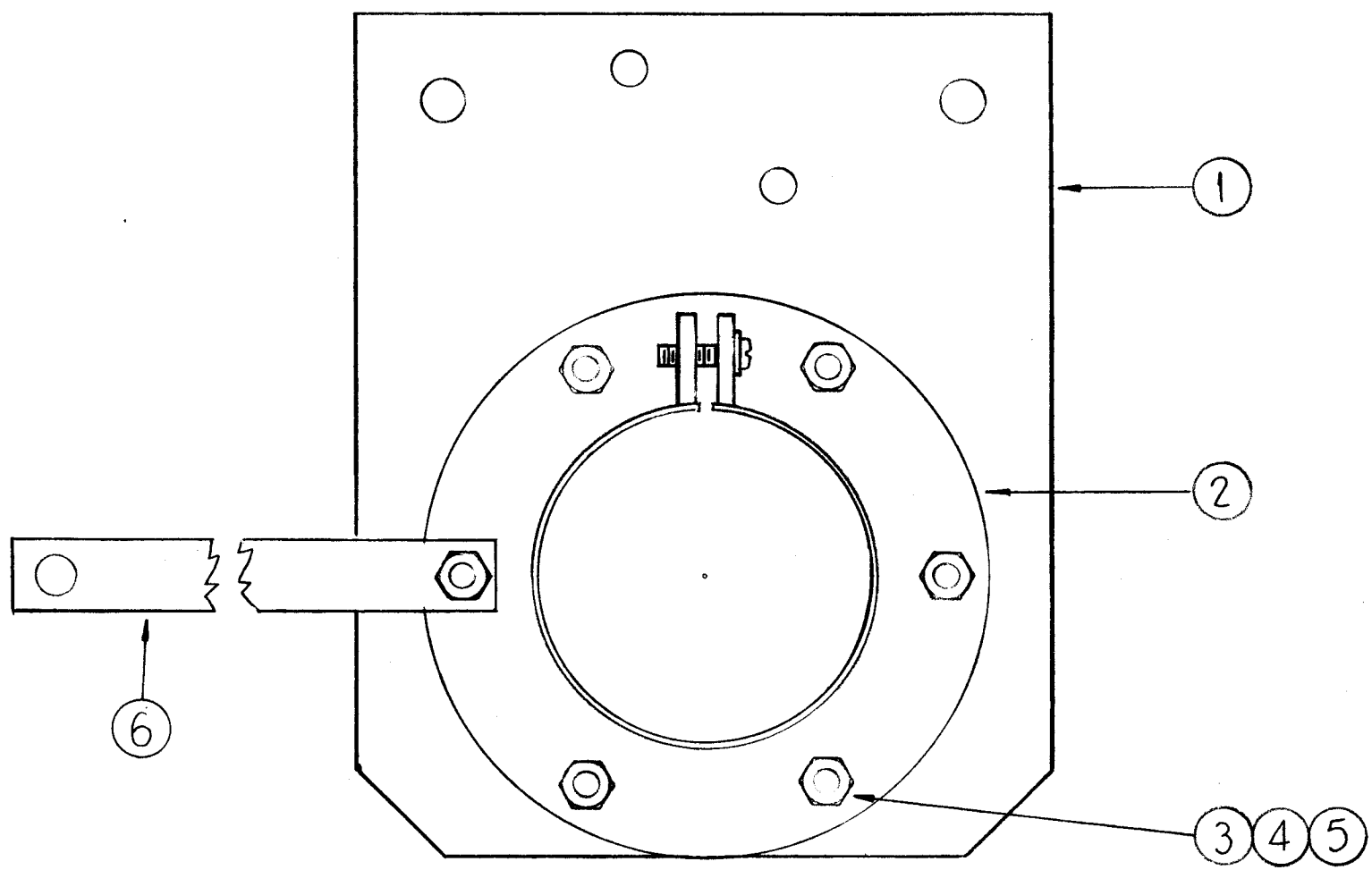

1	6	MS-202-8-762	Strap
6	5	LW508MRN	Lockwasher, Split
6	4	NTH0832BN10	Nut, Hex
6	3	SCBP0832BN10	Screw, Machine, Phillips
1	2	PO-185-45	Flange, Vacuum Capacitor
1	1	PX-625	Plate, Capacitor Mtg.

unlettered →

REQ.	ITEM	PART NO.	DESCRIPTION	SYMBOL
			THE TECHNICAL MATERIEL CORP. MAMARONECK, NEW YORK	
			INSULATOR & FLANGE ASS'Y. (UNLETTERED) KIT-125	
			MATERIAL	
			STOCK SIZE	
			TYPE & TEMPER	
			HEAT TREAT. SPEC.	
			FINISH & SPEC. NO.	
			ELEC. DES. APP. MECH. DES. APP.	

SYM	DESCRIPTION	DATE	CH. NO.	DRAFTS	CHECKER	ENG. APP.
	UNLESS OTHERWISE SPECIFIED: DIMENSIONS ARE IN INCHES TOLERANCES ON FRACTIONS ± 1/64 DECIMALS ± .005 ANGLES ± 1/20					
	SCALE: <i>1/2"</i>					
	MAXIMUM ALLOWABLE TOLERANCES HAVE BEEN DETERMINED AND ANY DEVIATIONS WILL BE CAUSE FOR REJECTION. REMOVE ALL BURRS AND SHARP EDGES					

1	KIT-125			3-1-62
REQ. PER UNIT	MODEL	SECTION	ASS'Y. NO.	DATE
USED ON				

D. DiMatteo **RUZZO** *JMM*
 DRAWN CHECKED FINAL APPROVAL
DB *aa* **A-2345**
 ELEC. DES. APP. MECH. DES. APP.