

REQ. PER. UNIT	USED ON			A-2117
	MODEL	ASS'Y. NO.	DATE	
	AFC-1B		8-14-61	

THE CONTENTS OF THIS DRAWING ARE THE EXCLUSIVE PROPERTY OF THE TECHNICAL MATERIEL CORP. ITS UNAUTHORIZED USE OR REPRODUCTION IN WHOLE OR IN PART IS STRICTLY FORBIDDEN.

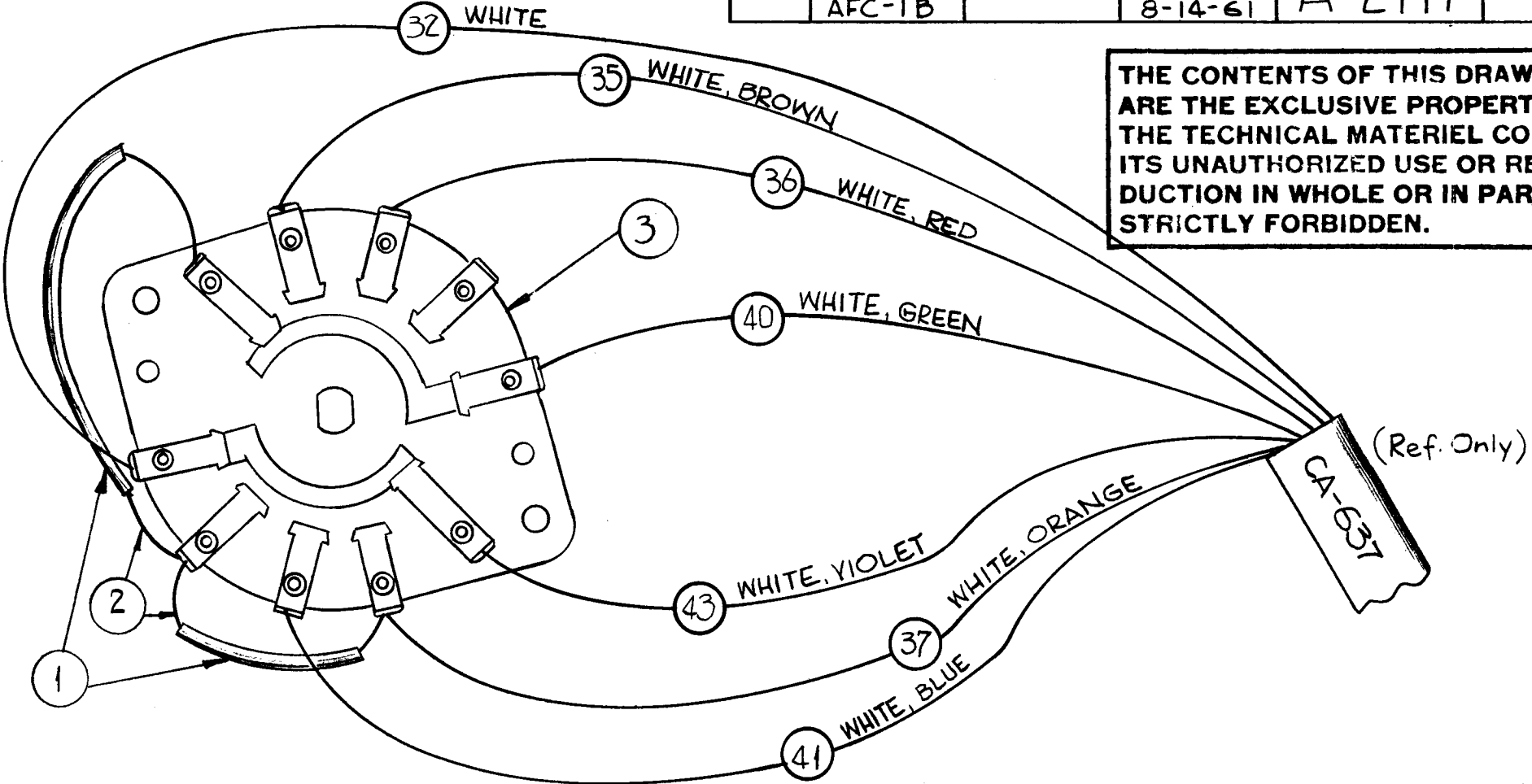

X	4	BS-100	SOLDER, SOFT
1	3	SW-120	SWITCH ROTARY OAK TYPE
	2	WL-100-7	WIRE, BUSS BAR
	1	PX-104-4-034	INSULATION, SLEEVING

ISSUE	ITEM	CHANGED FROM	DATE	CH. NO.	DRAFTS	CHECKER	ENG. APP.
TOLERANCES			SCALE:				
DEC. DIM. ±			MAXIMUM ALLOWABLE TOLERANCES HAVE BEEN DETERMINED AND ANY DEVIATIONS WILL BE CAUSE FOR REJECTION. REMOVE ALL BURRS AND SHARP EDGES				
FRAC. DIM. ±							
ANGULAR DIM. ±							

REQ.	ITEM	PART NO.	DESCRIPTION	SYMBOL
THE TECHNICAL MATERIEL CORP. MAMARONECK, NEW YORK				
AGC SWITCH(S2) WIRING ASS'Y MODEL ASS'Y AFC-1B				
			R. UZZO	<i>[Signature]</i>
			DRAWN	CHECKED
			<i>[Signature]</i>	<i>[Signature]</i>
			TYPE & TEMPER	HEATTREAT. SPEC.
			FINISH & SPEC. NO.	ELEC. DES. APP
				MECH. DES. APP

A-2117

REQ. PER UNIT	USED ON			A-2182
	MODEL	ASSY. NO.	DATE	
1	TER-25K	AX-277	9-26-61	

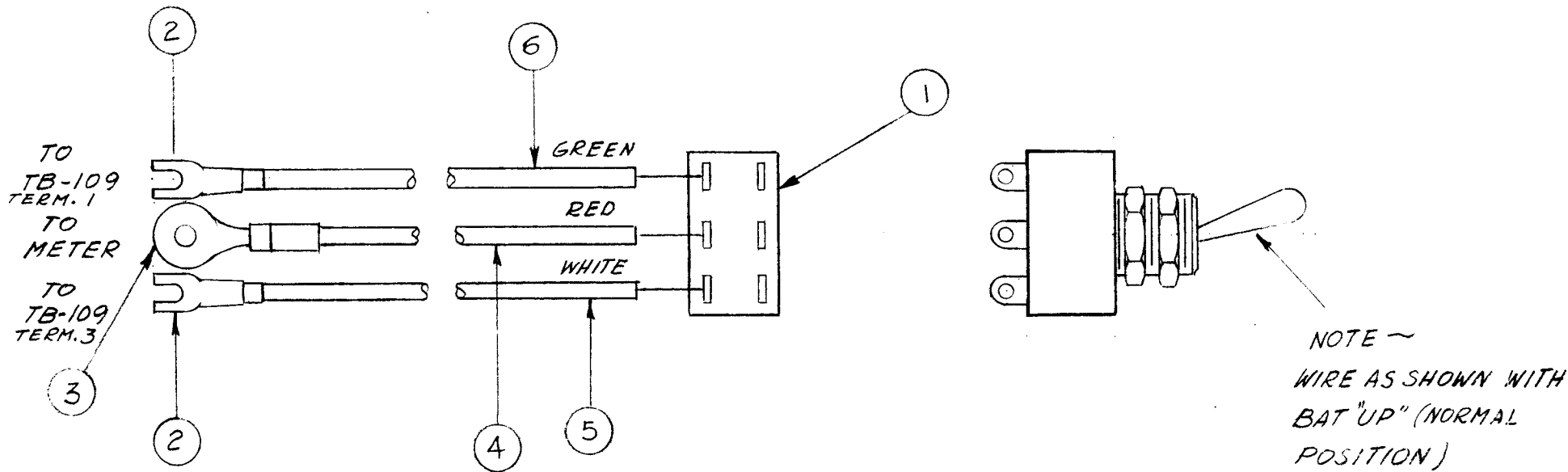

X	7	BS-100	SOLDER, SOFT	
5"	6	MWC18(16)U5	CABLE, INSULATED	GRN.
4"	5	MWC18(16)U9	CABLE, INSULATED	WH.
5"	4	MWC18(16)U2	CABLE, INSULATED	RED
1	3	TE-156-32953	TERMINAL, SOLDER LESS	
2	2	TE-120-2	LUG, SPADE	
1	1	ST-105	SWITCH TOGGLE	

ISSUE	ITEM	CHANGED FROM	DATE	CH. NO.	DRAFTS	CHECKER	ENG. APP.	REQ.	ITEM	PART NO.	DESCRIPTION	SYMBOL	
TOLERANCES								THE TECHNICAL MATERIEL CORP. MAMARONECK, NEW YORK SWITCH ASS'Y, FORWARD REFLECTED POWER					
DEC. DIM. ±			SCALE:					G.D.L.		DRAWN		CHECKED	FINAL APPROVAL
FRAC. DIM. ±			MAXIMUM ALLOWABLE TOLERANCES HAVE BEEN DETERMINED AND ANY DEVIATIONS WILL BE CAUSE FOR REJECTION.					aa		MECH. DES. APP		A-2182	
ANGULAR DIM. ±			REMOVE ALL BURRS AND SHARP EDGES					FINISH & SPEC. NO.		ELEC. DES. APP			