

A-2050 A

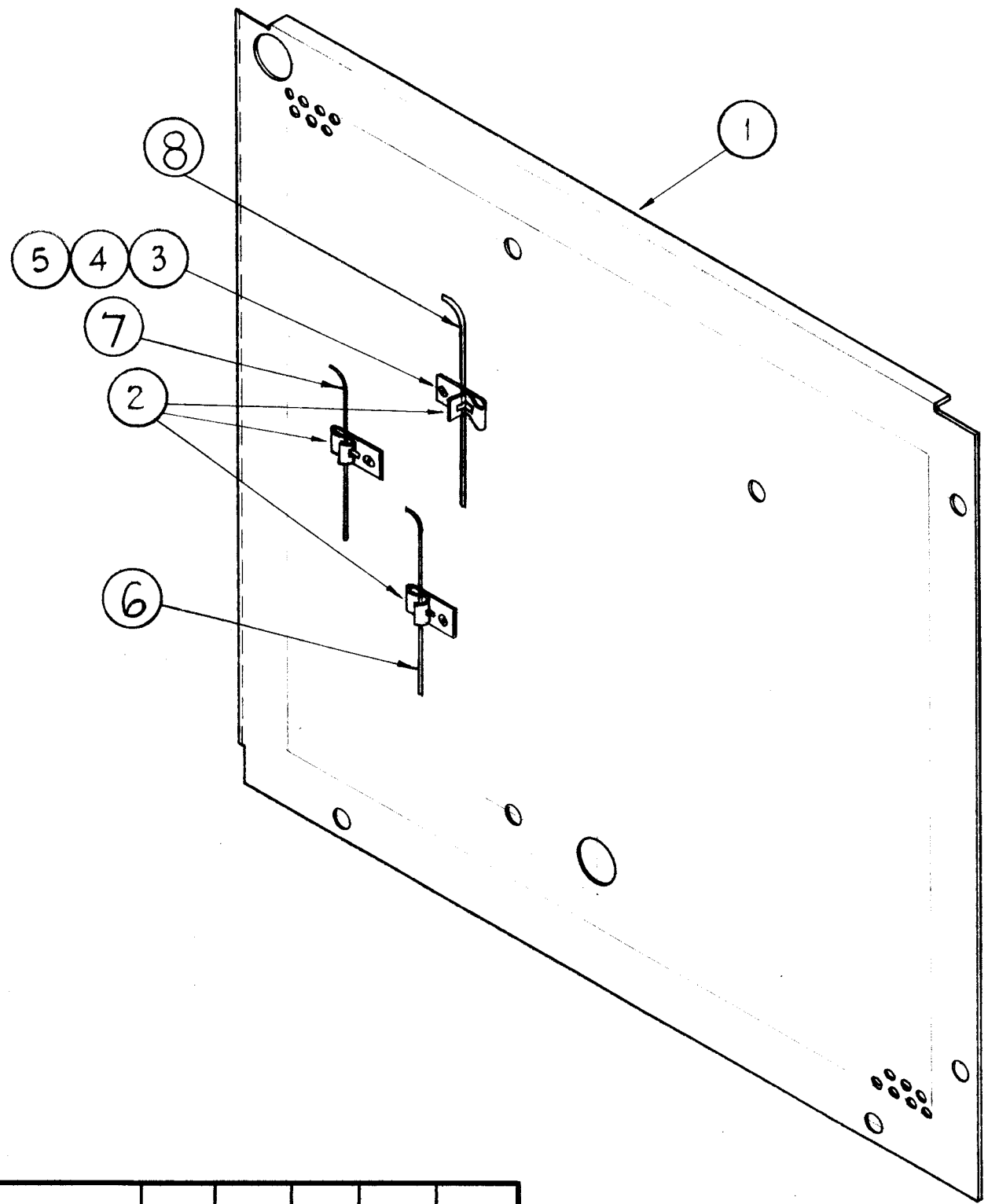

1	8	WR-100-19	WRENCH, HEX # 6	
1	7	WR-100-18	WRENCH, HEX # 8	
1	6	WR-100-5	WRENCH, HEX #10	
3	5	NTH0440BN6	NUT, HEXAGON	
3	4	LWEO4LRN	LOCKWASHER, EXTERNAL TOOTH	
3	3	SCBS0440BN4	SCREW, MACHINE	
3	2	CU-103-1	CLIP, SPRING	
1	1	MS-2415	TOP COVER, R.F. DECK	

REQ. ITEM	PART NO.	DESCRIPTION	SYMBOL
		THE TECHNICAL MATERIEL CORP. MAMARONECK, NEW YORK	
STOCK SIZE			
		ASS'Y, TOP COVER, R.F. DECK	
MATERIAL			
		J.C. Biele	
TYPE & TEMPER	HEAT TREAT. SPEC.	DRAWN	CHECKER
			FINAL APPROVAL
FINISH & SPEC. NO.		ELEC. DES. APP.	MECH. DES. APP.

SYM	DESCRIPTION	DATE	CH. NO.	DRAFTS	CHECKER	ENG. APP.
A	Item 4 was LWEO4LRN Items, 6, 7, 8 Added	2961	4110	RU	JCB	
UNLESS OTHERWISE SPECIFIED:		SCALE: 1/2, Do Not Scale				
DIMENSIONS ARE IN INCHES		MAXIMUM ALLOWABLE TOLERANCES HAVE BEEN DETERMINED AND ANY DEVIATIONS WILL BE CAUSE FOR REJECTION. REMOVE ALL BURRS AND SHARP EDGES				
TOLERANCES ON FRACTIONS ± 1/64 DECIMALS ± .005 ANGLES ± 1/2°						

1	CHG-1			2-1-61
REQ. PER UNIT	MODEL	SECTION	ASS'Y. NO.	DATE
USED ON				