

A-2040 C

Winding Machine Data
 Cam- .125
 Cam- Gear-49
 Driver-95
 Winding
 Total turns-44
 Tap At - 9 Turns From Start

PROCEDURE

1. Secure Terminals (items 4&5) to coil form (item 1) With Insulex (item 9)
2. Wind Required Number of turns of item 7 on coil form and Bring out Tap When Required.
3. Stake Coil ends to Coil Form with Q-Max (item 8).
4. Solder Coil Leads & Terminal Lug (item 11) to Term.
5. Bake Coil For 1/2 Hour at 210° F.
6. Paint Coil With Insulex (item 9)
7. Do Not Allow Insulex To Form On Top End of Coil Form where Bushing will be assembled.
8. Test Unit as per Specs. and Schematic, Without Core. (Use Boonton Q-Meter Model 160A or Equiv.)
9. Items 2,3, & 6 to be left as a separate assembly which will be inserted, but not secured in coil form.

Test Specs (w/o Core)
 L-28, ± 3 Microhenries
 Q-60 or Greater At Test Freq.
 Test Freq.-2.5 mc
 Oper. Freq. -1.75 to 3.75 mc

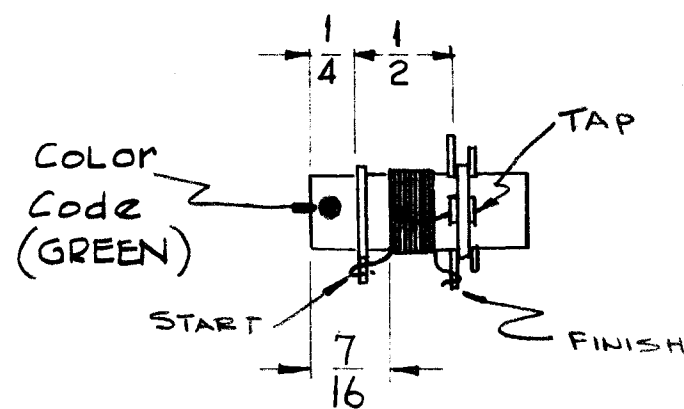
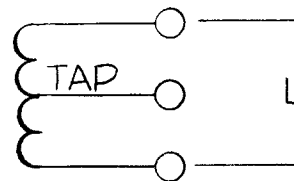
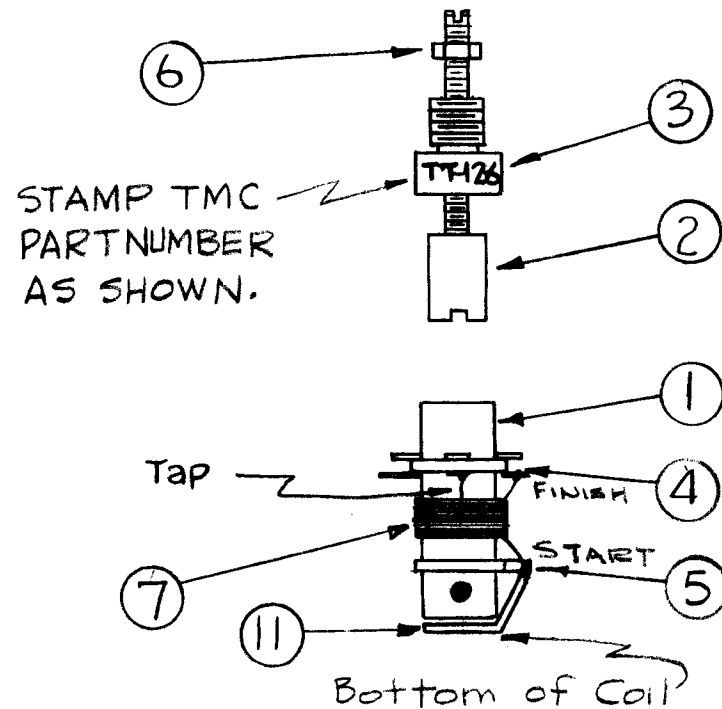

1	11	TE-104-3	TERMINAL, LOCKING
X	10	BS-100	Solder, Soft
X	9	GL-104-2	Insulex, U-85
X	8	GL-102	Lacquer, Q-Max.
X	7	WI-104-541DSQS	Wire
1	6	NTH0632BN8	Nut, Hex.
1	5	TE-153-2	Terminal, Ring Type
1	4	TE-170-3	Terminal, Collar
1	3	SM-145	Bushing, Coil Mtg.
1	2	CI-109-7	Core, Tuning
1	1	CF-123	Coil Form

REQ.	ITEM	PART NO.	DESCRIPTION	SYMBOL
THE TECHNICAL MATERIEL CORP. MAMARONECK, NEW YORK				
STOCK SIZE				
TT-126 ASS'Y				
TRANSFORMER				
MATERIAL				
TYPE & TEMPER		HEAT TREAT. SPEC.		FINAL APPROVAL
DRAWN		CHECKER		A-2040 C
FINISH & SPEC. NO.		ELEC. DES. APP. MECH. DES. APP.		

SYM	DESCRIPTION	DATE	CH. NO.	DRAFTS	CHECKER	ENG. APP.
C	POSITION OF IT. 5 REVERSED	9.22.61	12434	JB		
B	ITEM 3 WAS SM110	3-6-63	8380	RC		
A	ITEM 11 WAS TE-116-4	1-24-62	6245	G.S.		

UNLESS OTHERWISE SPECIFIED:
 DIMENSIONS ARE IN INCHES
 TOLERANCES ON FRACTIONS ± 1/64 DECIMALS ± .005 ANGLES ± 1/20

SCALE:
 MAXIMUM ALLOWABLE TOLERANCES HAVE BEEN DETERMINED AND ANY DEVIATIONS WILL BE CAUSE FOR REJECTION.
 REMOVE ALL BURRS AND SHARP EDGES

1	CHG-1	TI116	12-14-60
REQ. PER UNIT	MODEL	SECTION	ASS'Y. NO. DATE
USED ON			