

A-2027

STAMP CAN AS SHOWN 1/8 HIGH BLACK GOTHIC.
 NOTE~STAMP TMC INSIGNIA & APPROVAL
 ON SIDE OF CAN.

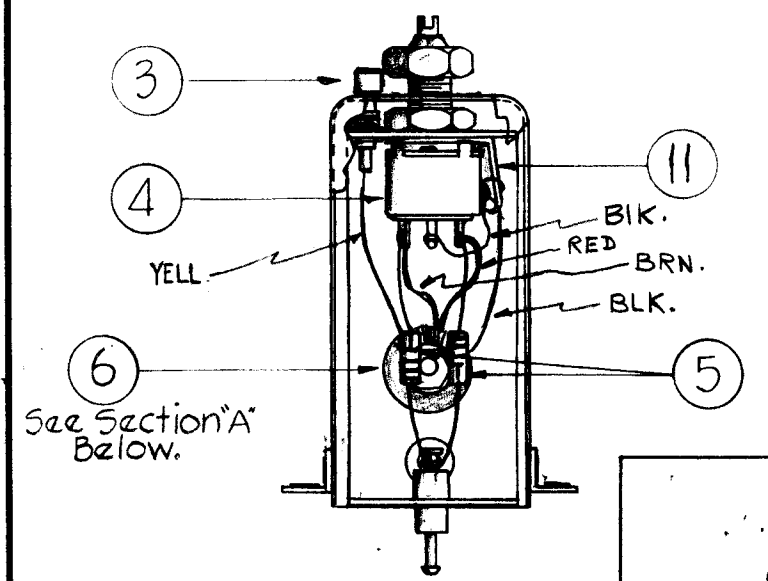

See Section "A" Below.

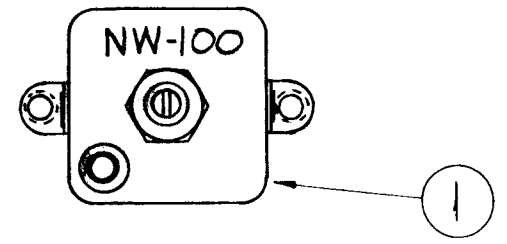
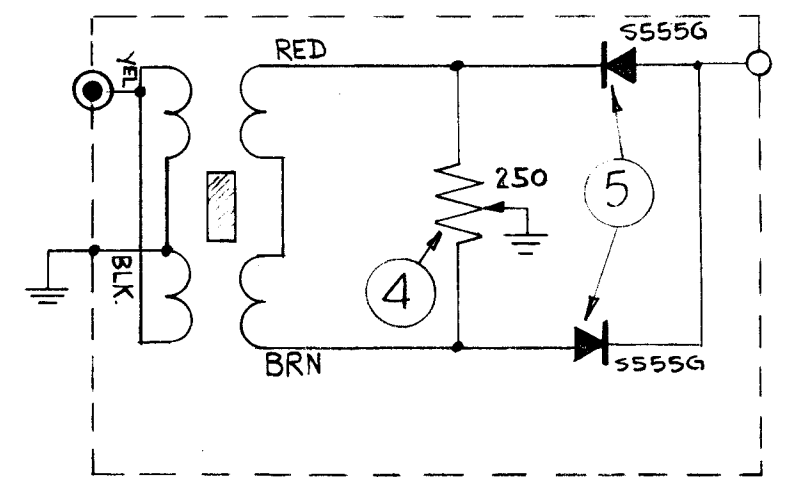
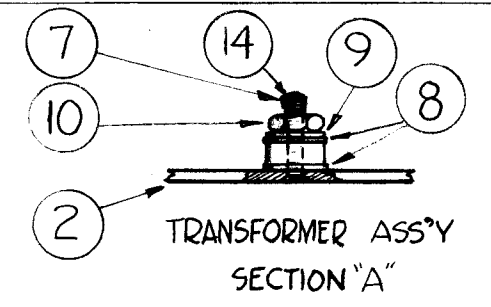
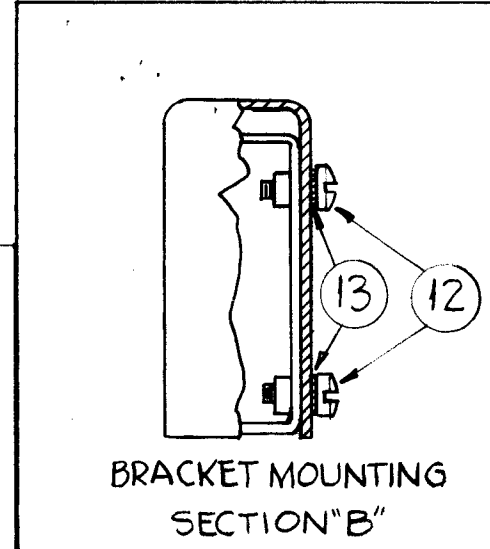

X	15	BS-100	SOLDER, SOFT	
X	14	GL-105	GLYPTAL	
2	13	LWE04MRN	LOCKWASHER, EXT.	
2	12	SCBS0440BN5	SCREW, MACHINE	
1	11	TE-104-5	LUG, GROUND	
1	10	NTH0440BN6	NUT, HEX	
1	9	FW04MRN	WASHER, FLAT	
2	8	GA-140-13N6	GASKET	
1	7	SCFS0440BN9	SCREW, MACHINE	
1	6	TF-172	TRANSFORMER	
2	5	DD-102-1	DIODE	
1	4	RV106UX8B251A	RESISTOR, VARIABLE, 1/2 W.	
1	3	JJ-154	CONNECTOR, RECEPTACLE	
1	2	MS-2436	BRACKET	
1	1	A-1997	CAN ASSEMBLY	

REQ.	ITEM	PART NO.	DESCRIPTION	SYMBOL
THE TECHNICAL MATERIEL CORP. MAMARONECK, NEW YORK NETWORK, BALANCE MODULATOR NW-100 ASS'Y.				
STOCK SIZE				
MATERIAL				
TYPE & TEMPER		HEAT TREAT. SPEC.	DRAWN	CHECKER
FINISH & SPEC. NO.		ELEC. DES. APP.	MECH. DES. APP.	FINAL APPROVAL
				A-2027
				A

A		ITEM 4 WAS RV106UX8B251A CHANGED SCHEMATIC TO CONFORM WITH CK-447	2-8-61	AD66	M.A.F.	OCB	SFM	
SYM	DESCRIPTION	DATE	CH. NO.	DRAFTS	CHECKER	ENG. APP.		
UNLESS OTHERWISE SPECIFIED: DIMENSIONS ARE IN INCHES TOLERANCES ON FRACTIONS ± 1/64 DECIMALS ± .005 ANGLES ± 1/20		SCALE: MAXIMUM ALLOWABLE TOLERANCES HAVE BEEN DETERMINED AND ANY DEVIATIONS WILL BE CAUSE FOR REJECTION. REMOVE ALL BURRS AND SHARP EDGES		1				CHG-1
		REQ. PER UNIT	MODEL	SECTION	ASS'Y. NO.	DATE	11-22-60	
USED ON								