

IF IT IS FOUND DESIRABLE TO CHANGE ANY TOLERANCE OR OTHER DETAIL SPECIFIED ON THIS DRAWING NOTIFY THE PURCHASER PROMPTLY.

MAXIMUM ALLOWABLE TOLERANCES HAVE BEEN DETERMINED AND DEVIATIONS WILL BE CAUSE FOR REJECTION. REMOVE ALL BURRS AND SHARP EDGES

RELEASED

A-262

PRESS FIT

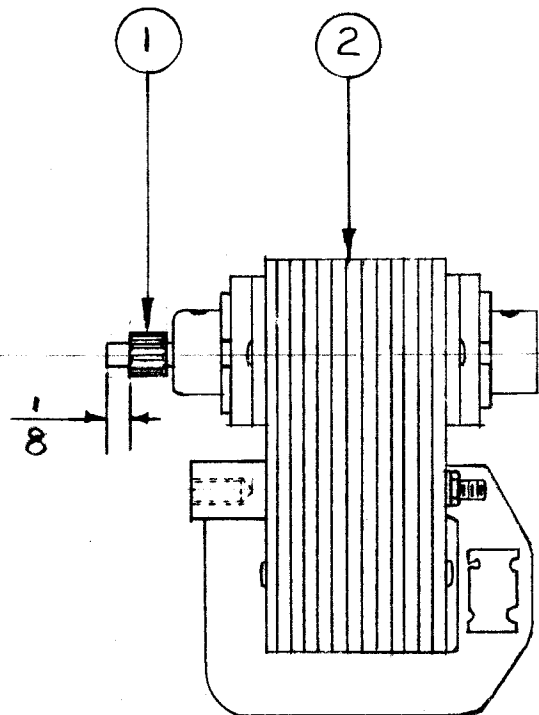
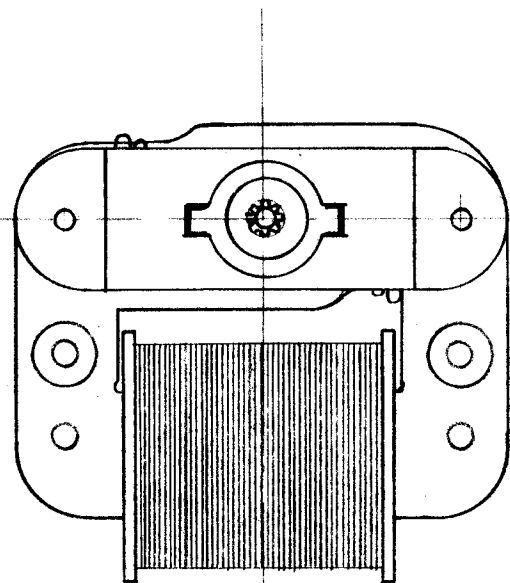

1	2	MO-102	MOTOR	
1	1	GR-106	PINION GEAR	
REQ.	ITEM	PART NO.	DESCRIPTION	SYMBOL
—ff—			THE TECHNICAL MATERIEL CORP.	
STOCK SIZE			MAMARONECK. NEW YORK	
—ff—		—ff—	MOTOR ASSEMBLY	
MATERIAL		WEIGHT PER PC.		
—ff—			16 11-18-52	
TYPE & TEMPER			DRAWN	MECH. DES. APP.
—ff—			CHECKED	FINAL APPROVAL
HEAT TREAT. SPEC.			A-262	
—ff—				
FINISH & SPEC. NO.				

ISSUE	ITEM	CHANGED FROM	DATE	CN. NO.	DRAFTS	CHECKER	ENG. APP.
TOLERANCES		SCALE: FULL SIZE					
ALL OTHERS	DEC. DIM. ± FRAC. DIM. ± ANGULAR DIM. ±	DRILL, PUNCH, COMMERCIAL STOCK SIZES AND MANUFACTURERS TOLERANCES ARE NOT INCLUDED.					

CK-2	168	A-267	11-18-52
MODEL	PROJECT NO.	ASS'Y. NO.	DATE
USED ON			