

A-1667 B

**NOTICE TO PERSONS RECEIVING THIS DRAWING**

THE TECHNICAL MATERIEL CORPORATION claims proprietary right in the material disclosed hereon. This drawing is issued in confidence for engineering information only and may not be reproduced or used to manufacture anything shown hereon without permission from THE TECHNICAL MATERIEL CORPORATION to the user. This drawing is loaned for mutual assistance and is subject to recall at any time.

Property of:  
**THE TECHNICAL MATERIEL CORPORATION**  
 MAMARONECK, NEW YORK

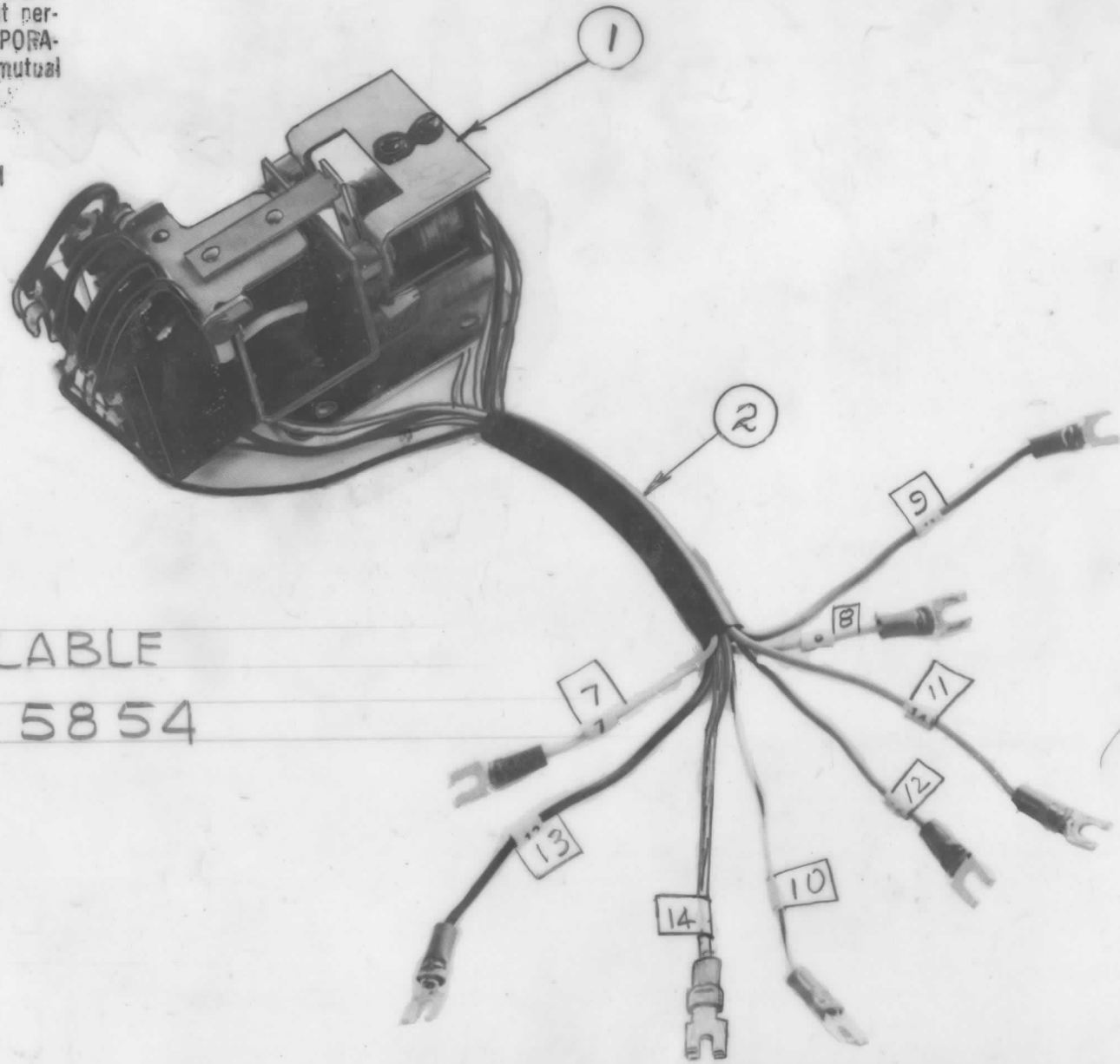

NO LONGER AVAILABLE  
 REPLACE BY A 5854

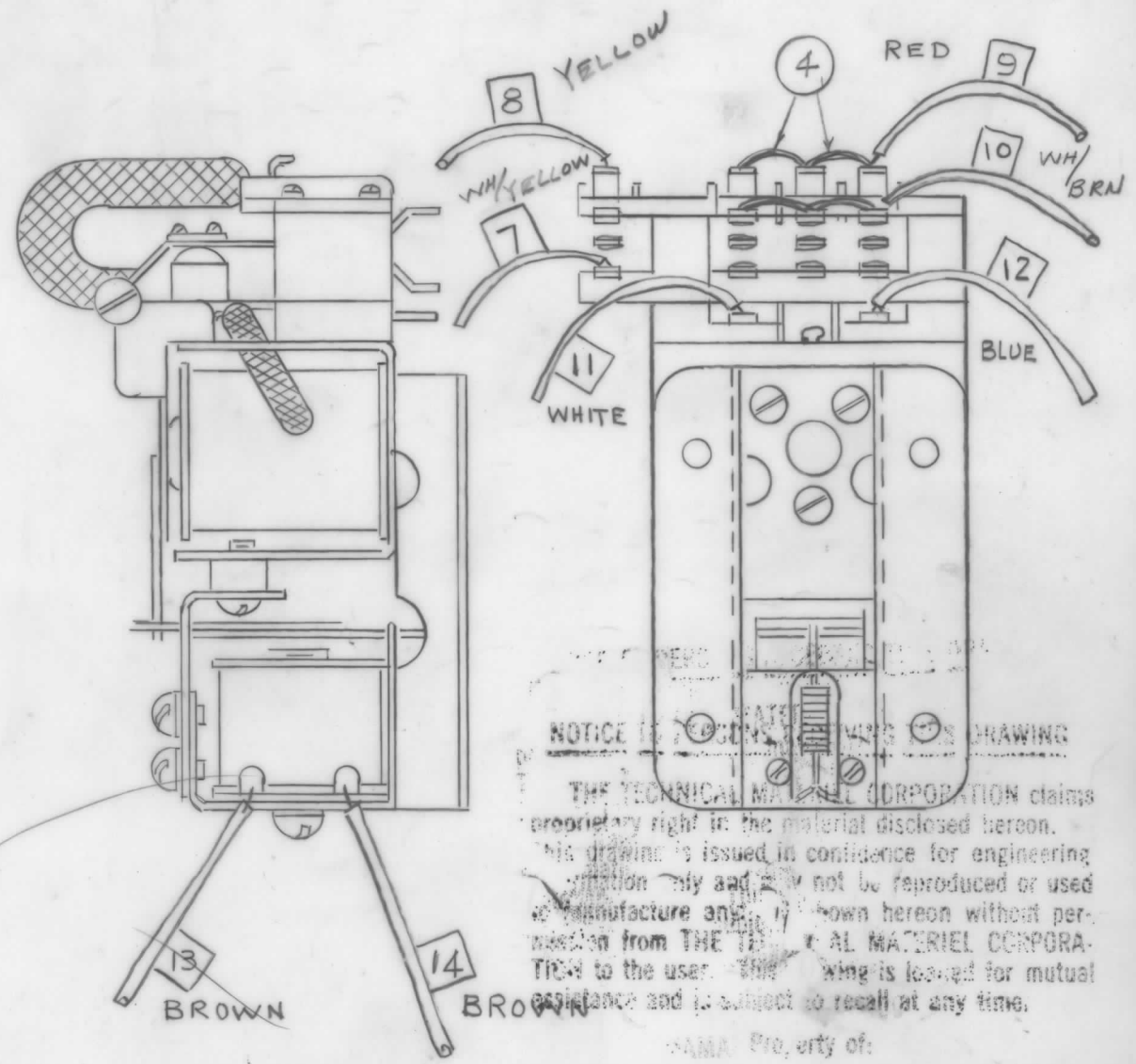

**NOTICE TO PERSONS RECEIVING THIS DRAWING**

THE TECHNICAL MATERIEL CORPORATION claims proprietary right in the material disclosed hereon. This drawing is issued in confidence for engineering information only and may not be reproduced or used to manufacture anything shown hereon without permission from THE TECHNICAL MATERIEL CORPORATION to the user. This drawing is loaned for mutual assistance and is subject to recall at any time.

Property of:  
 THE TECHNICAL MATERIEL CORPORATION  
 MAMARONECK, NEW YORK

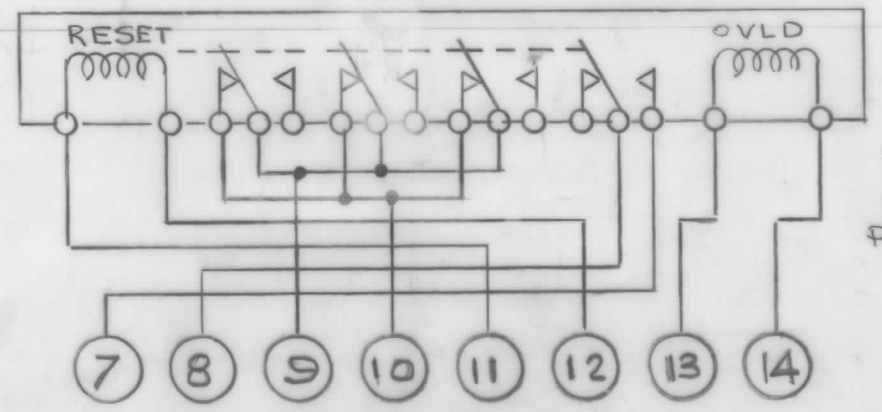

SHOWN IN RESET POSITION

|   |   |          |                      |
|---|---|----------|----------------------|
| X | 4 | WL-100-7 | WIRE, BUSS (SIZE 22) |
| X | 3 | BS-100   | SOLDER, SOFT         |
| 1 | 2 | CA-441   | CABLE- AR-100        |
| 1 | 1 | RL-122   | RELAY, ARMATURE      |

| REQ. ITEM   | PART NO. | DESCRIPTION | SYMBOL |
|---|----------|-------------|--------|
| <b>THE TECHNICAL MATERIEL CORP.</b><br>MAMARONECK, NEW YORK |          |             |        |
| <b>AR-100 ASS'Y. (K701)</b>                                 |          |             |        |
| <b>(PA PLATE OVL D RELAY ASSY)</b>                          |          |             |        |
| DRAWN   |          | AVC         | AMB    |
| CHECKED   |          | Jde         |        |
| FINAL APPROVAL  |          |             |        |
| FINISH & SPEC. NO.  |          | A-1667 B    |        |

| B              | NOTE: NO LONGER AVAIL. ADD | 10-31-85  | 22115   | G'DL   |         |           |
|----------------|----------------------------|---|---------|--------|---------|-----------|
| A              | 1 CLERICAL CHANGE          | 9.2.64  | -       | JJB    | OW      |           |
| ISSUE ITEM     | CHANGED FROM               | DATE  | CH. NO. | DRAFTS | CHECKER | ENG. APP. |
| TOLERANCES     |                            | SCALE:  |         |        |         |           |
| DEC. DIM. ±    |                            | MAXIMUM ALLOWABLE TOLERANCES HAVE BEEN DETERMINED AND ANY DEVIATIONS WILL BE CAUSE FOR REJECTION. |         |        |         |           |
| FRAC. DIM. ±   |                            | REMOVE ALL BURRS AND SHARP EDGES  |         |        |         |           |
| ANGULAR DIM. ± |                            |   |         |        |         |           |

|               |         |             |            |         |
|---------------|---------|-------------|------------|---------|
| 1             | GPT-10K | AR-100      | AR-161     | 8-24-64 |
| REQ. PER UNIT | MODEL   | PROJECT NO. | ASS'Y. NO. | DATE    |
| USED ON       |         |             |            |         |