

A-1586

NOTICE TO PERSONS RECEIVING THIS DRAWING

THE TECHNICAL MATERIEL CORPORATION claims proprietary right in the material disclosed hereon. This drawing is issued in confidence for engineering information only and may not be reproduced or used to manufacture anything shown hereon without permission from THE TECHNICAL MATERIEL CORPORATION to the user. This drawing is loaned for mutual assistance and is subject to recall at any time.

Property of:
THE TECHNICAL MATERIEL CORPORATION
MAMARONECK, NEW YORK

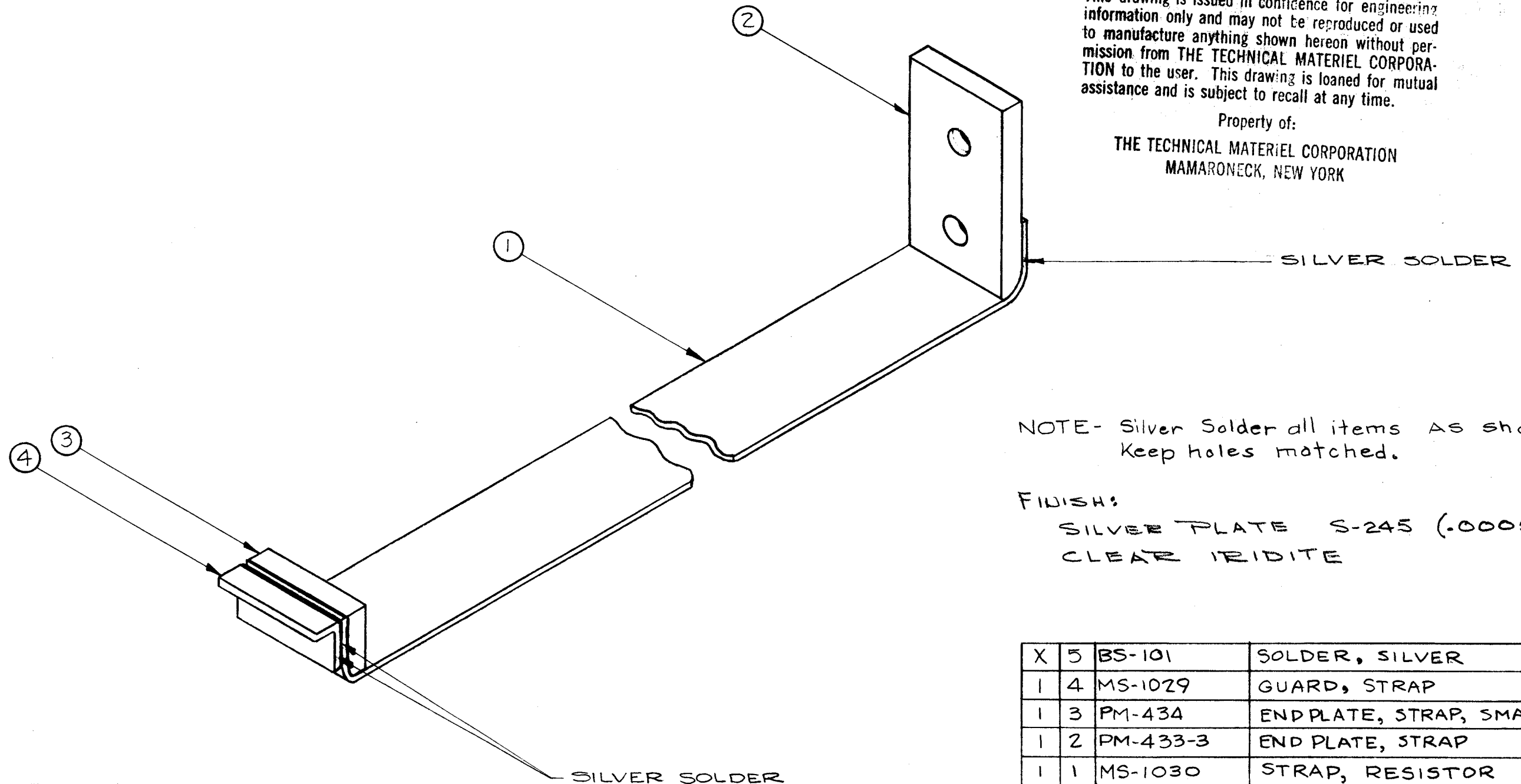

NOTE- Silver Solder all items AS shown, Keep holes matched.

FINISH:
SILVER PLATE S-245 (.0005) AND
CLEAR IRIDITE

X	5	BS-101	SOLDER, SILVER	
1	4	MS-1029	GUARD, STRAP	
1	3	PM-434	ENDPLATE, STRAP, SMALL	
1	2	PM-433-3	END PLATE, STRAP	
1	1	MS-1030	STRAP, RESISTOR	
REQ.	ITEM	PART NO.	DESCRIPTION	SYMBOL
			THE TECHNICAL MATERIEL CORP. MAMARONECK, NEW YORK	
STOCK SIZE			RESISTOR TOP STRAP ASS'Y (TER 5000-50,-70)	
MATERIAL				
		JCB-K		AW
TYPE & TEMPER		HEATTREAT. SPEC.	DRAWN	CHECKED
SEE NOTE			SG	A-1586
FINISH & SPEC. NO.		ELEC. DES. APP	MECH. DES. APP	

ISSUE	ITEM	CHANGED FROM	DATE	CH. NO.	DRAFTS	CHECKER	ENG. APP.
TOLERANCES		SCALE: <i>Do Not SCALE</i>		2	TER-5000-70		1-29-62
DEC. DIM. ±	FRAC. DIM. ±	ANGULAR DIM. ±	MAXIMUM ALLOWABLE TOLERANCES HAVE BEEN DETERMINED AND ANY DEVIATIONS WILL BE CAUSE FOR REJECTION: REMOVE ALL BURRS AND SHARP EDGES		2	TER-5000-50	1-8-59
		REQ. PER UNIT	MODEL	PROJECT NO.	ASSY. NO.	DATE	
		USED ON					