

# STANDARD DRAWING

REQ. PER UNIT  
4

USED ON  
ASSEMBLY NO.

MODEL  
TLI - I

DATE

A-1432

A

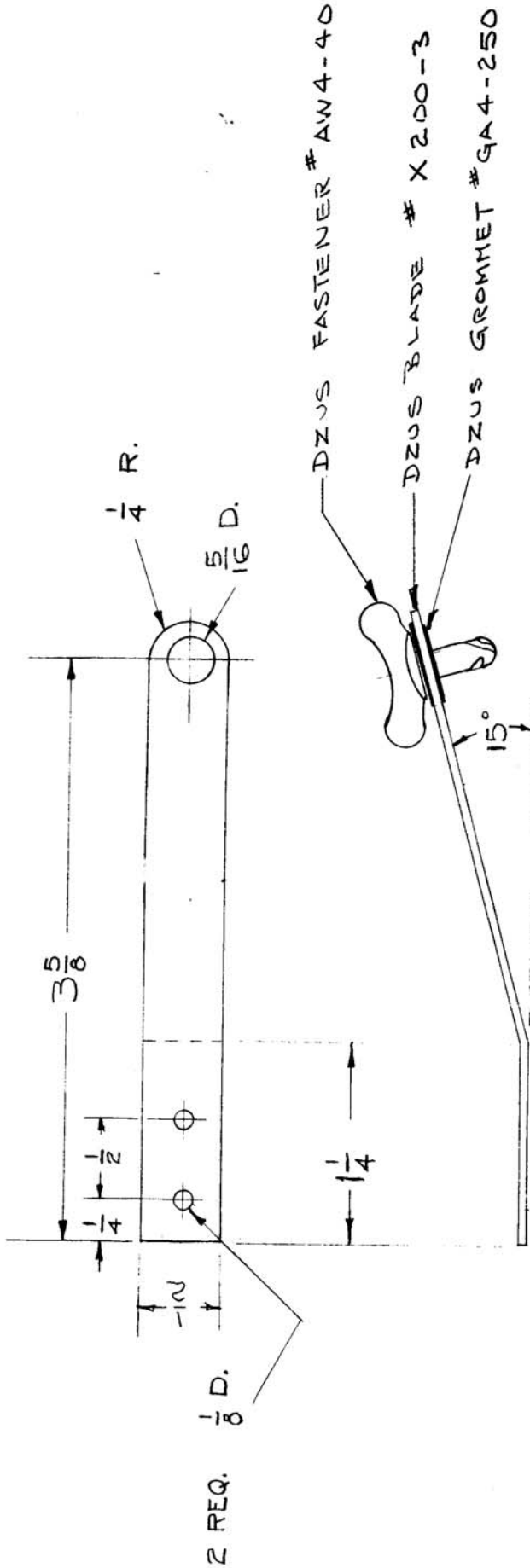

REF: DZUS FASTENER CO. INC.

REQ. ITEM	PART NO.	DESCRIPTION	SYMBOL
.045		THE TECHNICAL MATERIEL CORP. MAMARONECK, NEW YORK	
SPRING STEEL		EJECTOR BLADE ASSY.	
MATERIAL			
TYPE & TEMPER		6.24.57	
HEAT TREAT. SPEC.		6/24/57	
NONE			
FINISH & SPEC. NO.			
ELEC. DES. APP.			
MECH. DES. APP.			
FINAL APPROVAL			
A-1432			

DATE: 11/14/57  
 CH. NO. 16  
 DRAFTS CHECKER: JMW  
 ENG. APP. [Signature]  
 SCALE: #  
 MAXIMUM ALLOWABLE TOLERANCES HAVE BEEN DETERMINED AND ANY DEVIATIONS WILL BE CAUSE FOR REJECTION.  
 REMOVE ALL BURRS AND SHARP EDGES

ISSUE ITEM: A 1  
 FINISH DELE.  
 CHANGED FROM: 1/64  
 TOLERANCES: DEC. DIM. ± 1/64  
 FRAC. DIM. ± 1/64  
 ANGULAR DIM. ± 1/64