

|               |               |                  |
|---------------|---------------|------------------|
| REQ. PER UNIT | MODEL         | USED ON          |
| 1             | TCA 85/35 GDL | ASSY. NO. A-1174 |
|               |               | DATE             |
|               |               | A-1173           |

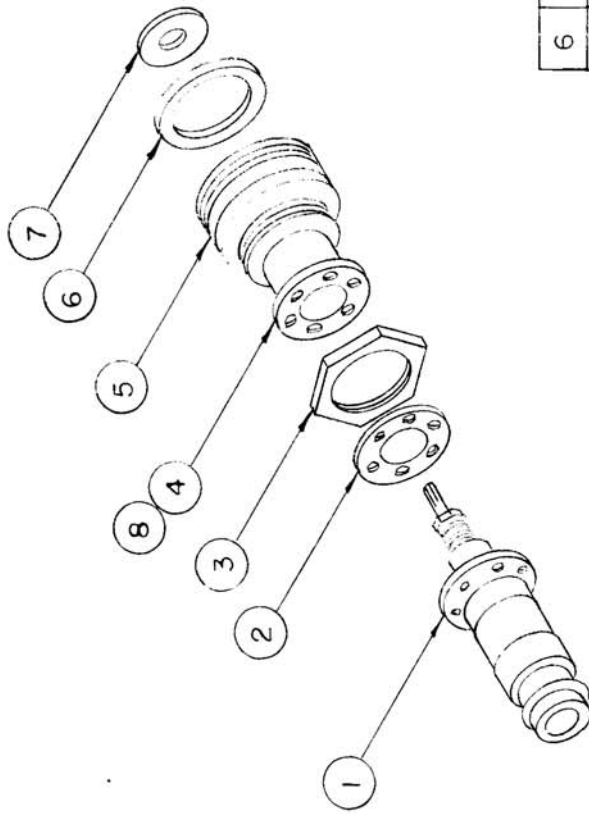

|   |   |             |                       |  |  |
|---|---|-------------|-----------------------|--|--|
| 6 | 8 | LWSO4MRS    | LOCKWASHER            |  |  |
| 1 | 7 | PX-106      | TEFLON WASHER #2      |  |  |
| 1 | 6 | GA-108      | GASKET                |  |  |
| 1 | 5 | SM-135      | ADAPTER               |  |  |
| 6 | 4 | SCPSO440BC5 | SCREW, MACHINE        |  |  |
| 1 | 3 | NT-103      | NUT, MOUNTING         |  |  |
| 1 | 2 | GA-135      | GASKET                |  |  |
| 1 | 1 | JJ-134      | CONNECTOR, RECEPTACLE |  |  |

|                    |          |             |        |
|--------------------|----------|-------------|--------|
| REQ. ITEM          | PART NO. | DESCRIPTION | SYMBOL |
| STOCK SIZE         |          |             |        |
| MATERIAL           |          |             |        |
| TYPE & TEMPER      |          |             |        |
| HEAT TREAT. SPEC.  |          |             |        |
| DRAWN              |          |             |        |
| CHECKED            |          |             |        |
| FINAL APPROVAL     |          |             |        |
| FINISH & SPEC. NO. |          |             |        |

|  |              |      |         |        |         |           |
|--|--------------|------|---------|--------|---------|-----------|
| ISSUE ITEM   | CHANGED FROM | DATE | CH. NO. | DRAFTS | CHECKER | ENG. APP. |
| TOLERANCES   |              |      |         |        |         |           |
| SCALE:   |              |      |         |        |         |           |
| MAXIMUM ALLOWABLE TOLERANCES HAVE BEEN DETERMINED AND ANY DEVIATIONS WILL BE CAUSE FOR REJECTION. REMOVE ALL BURRS AND SHARP EDGES |              |      |         |        |         |           |
| DEC. DIM. ±  |              |      |         |        |         |           |
| FRAC. DIM. ±   |              |      |         |        |         |           |
| ANGULAR DIM. ±   |              |      |         |        |         |           |

12-21-55  
 JAD  
 WSC  
 A-1173