

IF IT IS FOUND DESIRABLE TO CHANGE ANY TOLERANCE OR OTHER DETAIL SPECIFIED ON THIS DRAWING NOTIFY THE PURCHASER PROMPTLY.

MAXIMUM ALLOWABLE TOLERANCES HAVE BEEN DETERMINED AND DEVIATIONS WILL BE CAUSE FOR REJECTION. REMOVE ALL BURRS AND SHARP EDGES

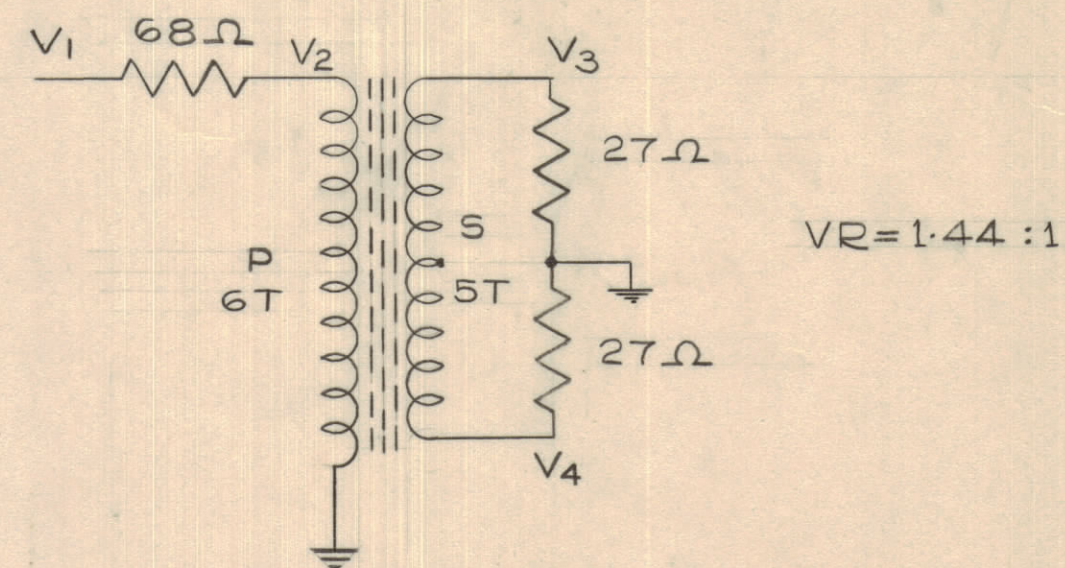

TEST DATA

F	TOLERANCE ±				AFTER POTTING						
	V1	V2	V3	V4	V2	V3	V4	V1	V2	V3	V4
2	1.0	.525	.225	.225	.02	.01	.01	1.0	.53	.21	.21
4	1.0	.52	.222	.222	"	"	"				
8	1.0	.52	.222	.222	"	"	"				
16	1.0	.53	.22	.218	"	"	"	1.0	.55	.205	.205
24	1.0	.545	.218	.215	"	"	"				
30	1.0	.55	.215	.21	"	"	"	1.0	.57	.2	.2

ABOVE VALUES APPLY TO UNPOTTED TRANSFORMER  
ALL MEASUREMENTS WITH HP. MODEL 410B VTVM.  
NOTE: DIFFERENCE BETWEEN V3 & V4 NOT TO EXCEED .01

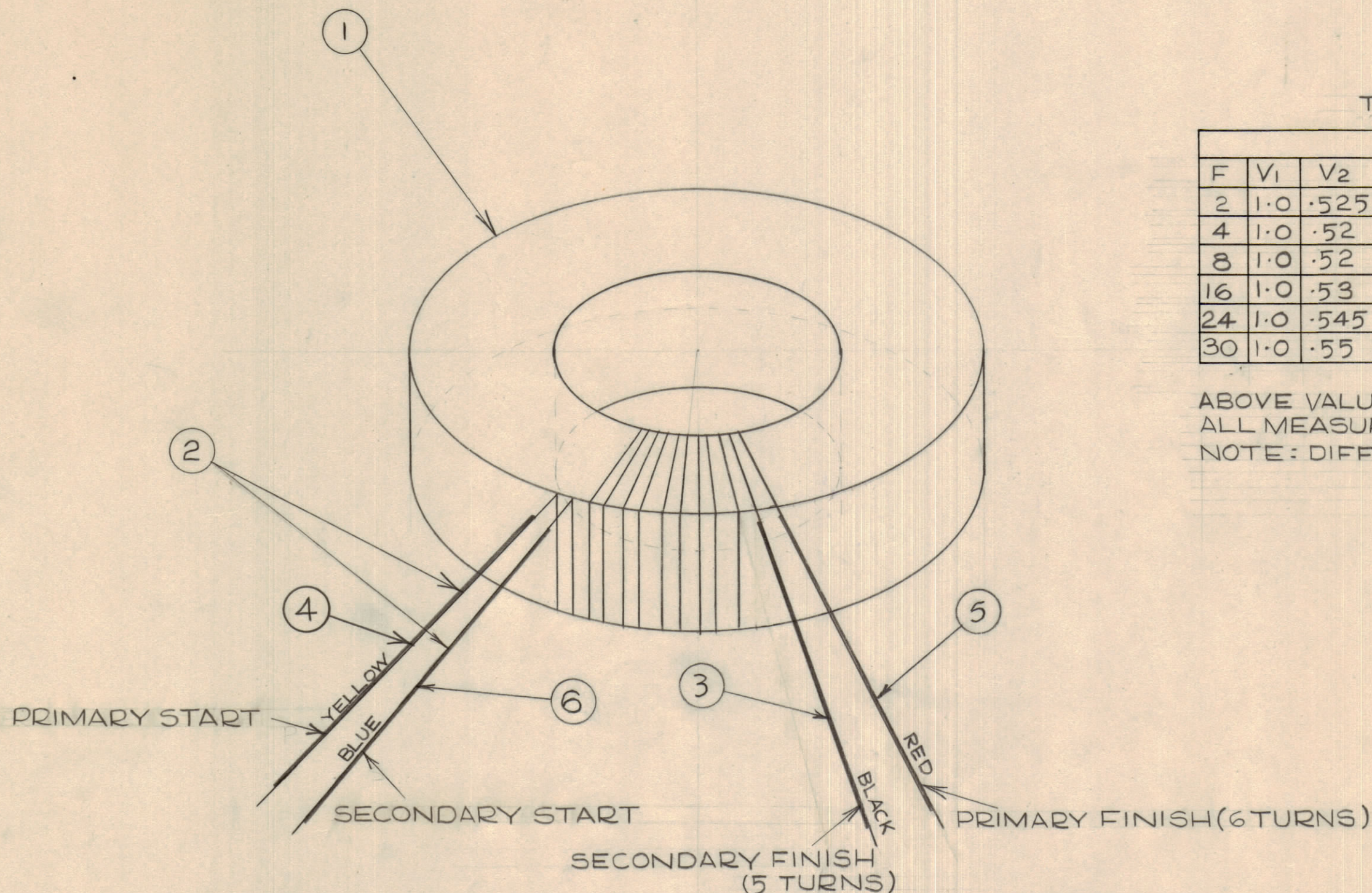

- STEP 1: 5 TURNS, #30 DCC WIRE - BIFILAR (2 WIRES SIDE BY SIDE).
- STEP 2: ONE ADDITIONAL TURN OF PRIMARY (6 TURNS TOTAL).
- STEP 3: COAT WINDINGS WITH RADIOCEMENT.
- STEP 4: POT IN 1-1/4" DIA. MOLD 1/2" THICK

NOTICE TO PERSONS RECEIVING THIS DRAWING

THE TECHNICAL MATERIEL CORPORATION claims proprietary right in the material disclosed hereon. This drawing is issued in confidence for engineering information only and may not be reproduced or used to manufacture anything shown hereon without permission from THE TECHNICAL MATERIEL CORPORATION to the user. This drawing is loaned for mutual assistance and is subject to recall at any time.

Property of:  
THE TECHNICAL MATERIEL CORPORATION  
MAMARONECK, NEW YORK

NOT TO BE RELEASED  
W/O AUTHORIZATION  
AUTH. BY: \_\_\_\_\_  
DATE: \_\_\_\_\_

REQ.	ITEM	PART NO.	DESCRIPTION	SYMBOL
A/R	6	PX-104-6-022	INSULATION SLEEVING (BLUE)	
A/R	5	PX-104-3-022	INSULATION SLEEVING (RED)	
A/R	4	PX-104-2-022	INSULATION SLEEVING (YELLOW)	
A/R	3	PX-104-1-022	INSULATION SLEEVING (BLACK)	
A/R	2	WI-10007	WIRE - #30 SINGLE POLY, SINGLE NYLON.	
1	1	CI10001-3	CORE - GRADE 3C	

STOCK SIZE		TMC (Canada) LIMITED OTTAWA ONTARIO	
MATERIAL		TRANSFORMER	
WEIGHT PER PC.		TR-083 (FOR DAC-6)	
TYPE & TEMPER		DCM	
HEAT TREAT. SPEC.		DRAWN	MECH. DES. APP.
FINISH & SPEC. NO.		CHECKED	FINAL APPROVAL

ISSUE	ITEM	CHANGED FROM	DATE	CN. NO.	DRAFTS	CHECKER	ENG. APP.
A	3	SCHEMATIC ALTERED	24		WHO	ELS	R.M.S.
	2	STEP 4, 1/2 THK ADDED	NOV				
	1	ITEMS 3, 4, 5, 6 ADDED TO B.O.M.	1960				

TOLERANCES		SCALE: NTS	
ALL OTHERS	DEC. DIM. ± FRAC. DIM. ± ANGULAR DIM. ±	DRILL, PUNCH, COMMERCIAL STOCK SIZES AND MANUFACTURERS TOLERANCES ARE NOT INCLUDED.	

DAC-6		OCT 20/59	
MODEL	PROJECT No.	ASS'Y. No.	DATE
USED ON			

A10237