

IF IT IS FOUND DESIRABLE TO CHANGE ANY TOLERANCE OR OTHER DETAIL SPECIFIED ON THIS DRAWING NOTIFY THE PURCHASER PROMPTLY.

MAXIMUM ALLOWABLE TOLERANCES HAVE BEEN DETERMINED AND DEVIATIONS WILL BE CAUSE FOR REJECTION. REMOVE ALL BURRS AND SHARP EDGES.

ISSUE	ITEM	CHANGED FROM	DATE	CN. No	DRAFT	CH'KR	ENG. APP.
B	1	B.O.M DELETED AND REWRITTEN. NOTES DELETED FROM F.O.F.D AND REWRITTEN. WINDING DIRECTION CHANGED	31 AUG 1960		WHD	AMS	<i>[Signature]</i>
C	2	IN B.O.M ITEMS 1 & 3 CI-10001-3 WAS CI-10002 BX-100-35 WAS BX-10035	26 JAN 1961		WHD	AMS	<i>[Signature]</i>
D	1	ITEM 2 WAS WI-10007	8-10-62 1965		G.S.		<i>[Signature]</i>
E	1	ITEM (9) ADDED	4-26-63 1963				<i>[Signature]</i>

NOT TO BE RELEASED W/O AUTHORIZATION
 AUTH. BY _____
 DATE: _____

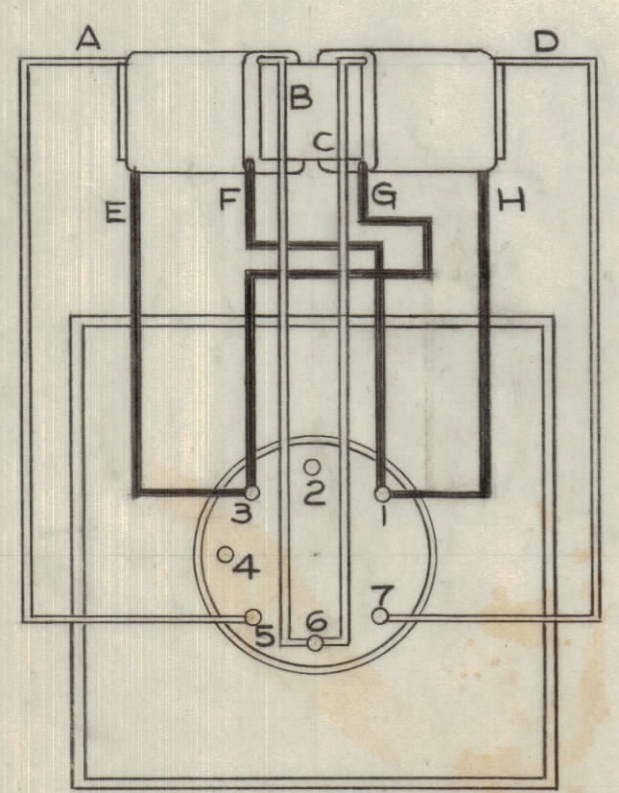
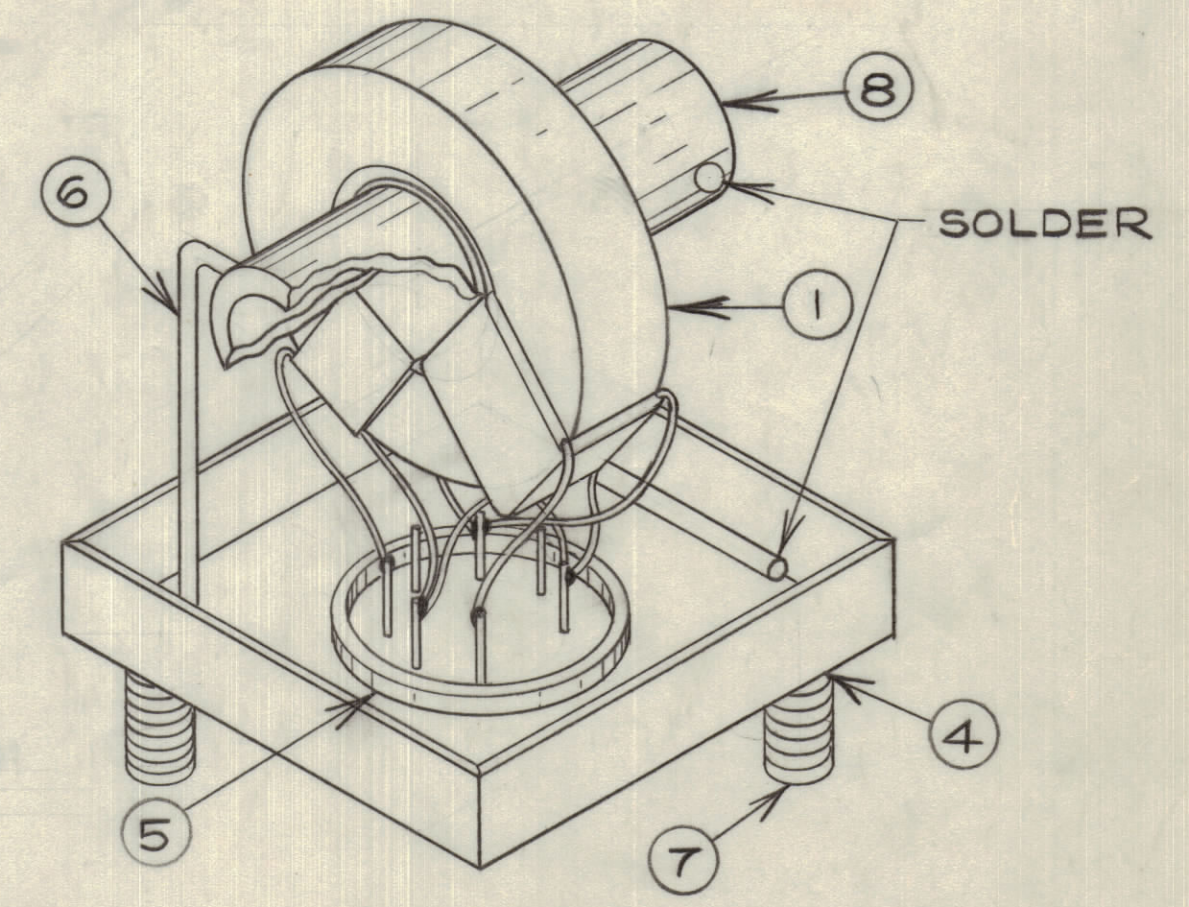
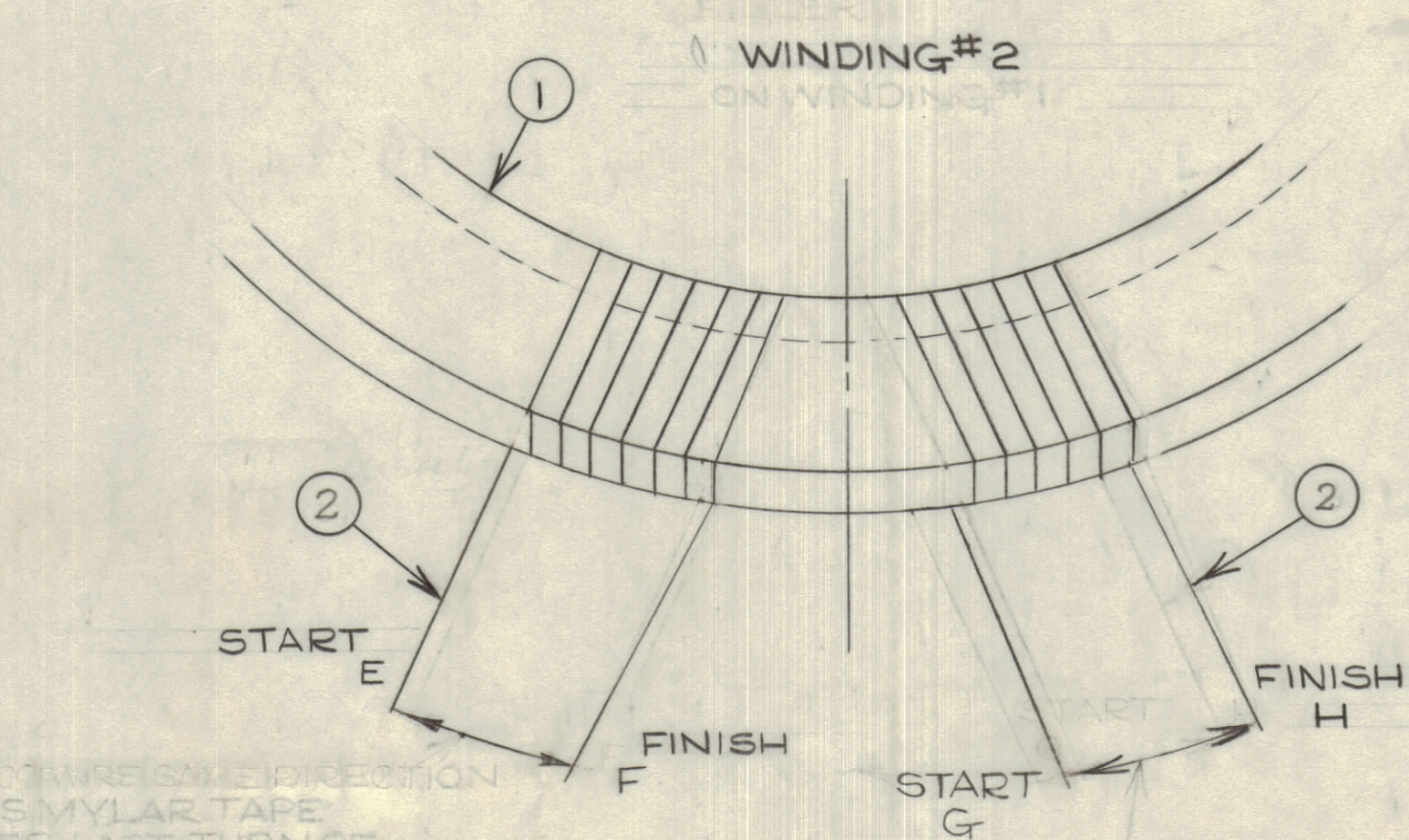
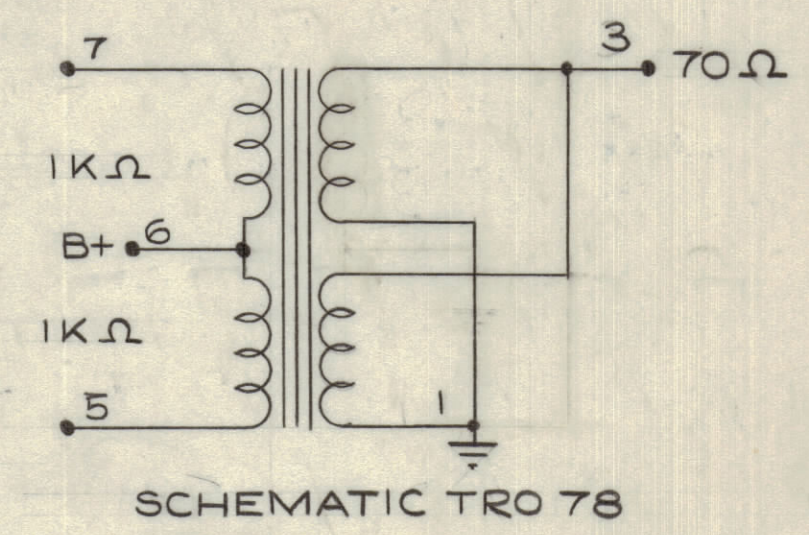
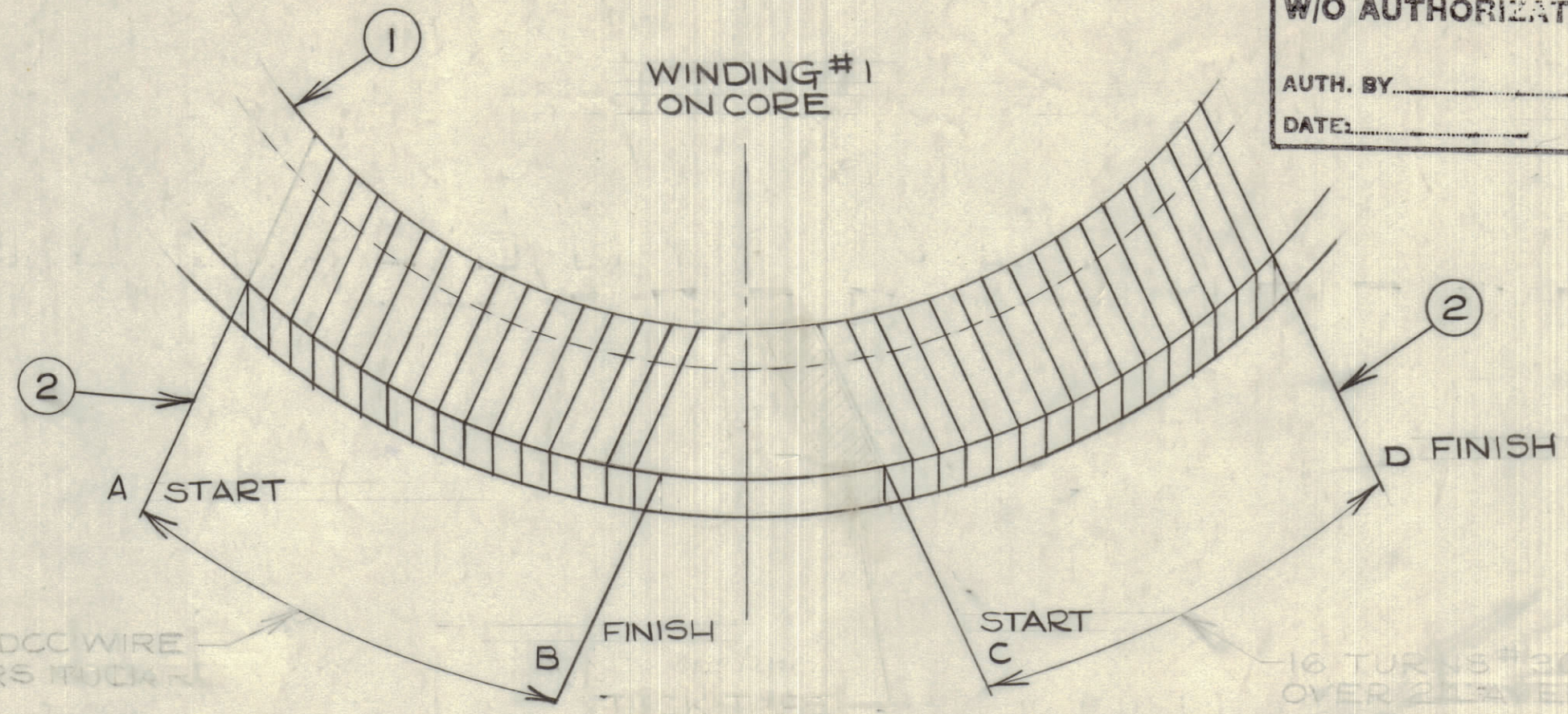

1. WIND TWO LAYERS OF MASKING TAPE ON CORE FOR EACH WINDING, ENSURE THAT TAPE IS TRUE TO CENTRE OF CORE. THE TWO WINDS OF TAPE SHOULD BE APPROXIMATELY 80° RELATIVE TO EACH OTHER & CLOSE TOGETHER ON THE INSIDE OF THE CORE
2. WIND 16 3/4 TURNS ANTICLOCKWISE TO THE RIGHT. SECURE WINDING, APPLY "Q" DOPE & ALLOW TO DRY. PULL BACK START & FINISH OF WINDING TO TOP FRONT EDGE OF THE CORE
3. WIND ON TWO LAYERS OF CLEAR MYLAR TAPE
4. WIND 6 3/4 TURNS ANTI-CLOCKWISE TO THE RIGHT, ENSURING THAT THE TURN NEAREST THE CENTRE OF THE TWO SECTIONS IS LAID EXACTLY ABOVE THE CORRESPONDING END TURN OF THE BOTTOM WINDING, & THAT ALL WINDINGS ARE PARALLEL TO THE TURNS OF THE OF THE BOTTOM WINDING. SECURE WINDING, APPLY "Q" DOPE & ALLOW TO DRY. PULL BACK START & FINISH OF BOTTOM WINDING TO BOTTOM FRONT EDGE OF CORE
5. WIND ON TWO LAYERS MASKING TAPE. APPLY "Q" DOPE LIBERALLY TO SIDES OF WINDING & OVER TAPE.
6. 2, 3, 4, & 5 IS APPLICABLE TO BOTH L.H. & R.H. WINDINGS

NOTICE TO PERSONS RECEIVING THIS DRAWING

THE TECHNICAL MATERIEL CORPORATION claims proprietary right in the material disclosed hereon. This drawing is issued in confidence for engineering information only and may not be reproduced or used to manufacture anything shown hereon without permission from THE TECHNICAL MATERIEL CORPORATION to the user. This drawing is loaned for mutual assistance and is subject to recall at any time.

Property of:
 THE TECHNICAL MATERIEL CORPORATION
 MAMARONECK, NEW YORK

REQ.	ITEM	PART NO.	DESCRIPTION	SYMBOL
4	R	9	GL-10003	ARALDITE HOT POTTING
1	8	CF10012	MANDREL	
2	7	BX-100-35	LID 3/8 LG STUD	
2	6	MS-10259	STABILISER	
1	5	TS-10004	MULTI-TERM HEADER HERMET.	
4	4	MS-10258	BASE MOUNTING	
3	3	BX-100-35	CAN	
2	2	WI-10007	WIRE #30 SINGLE POLY-SINGLE NYLON	
1	1	CI-10001-3	CORE - 3C	

REQ.	ITEM	PART NO.	DESCRIPTION	SYMBOL
TMC (Canada) LIMITED OTTAWA ONTARIO				
TRANSFORMER				
TR-078				
DCM			<i>[Signature]</i>	
DRAWN		ELEC. DES. APP.		MECH. DES. APP.
CHECKED			FINAL APPROVAL	
A10182 E				

ISSUE	ITEM	CHANGED FROM	DATE	CN. NO.	DRAFTS	CHECKER	ENG. APP.
TOLERANCES							
ALL OTHERS				SCALE: NTS			
DEC. DIM. ±				DRILL, PUNCH, COMMERCIAL STOCK			
FRAC. DIM. ±				SIZES AND MANUFACTURERS			
ANGULAR DIM. ±				TOLERANCES ARE NOT INCLUDED.			

MODEL	PROJECT No.	ASS'Y. No.	DATE
AMC 6-5	CE 646		DEC 16/58
USED ON			

A-10182 E