

IF IT IS FOUND DESIRABLE TO CHANGE ANY TOLERANCE OR OTHER DETAIL SPECIFIED ON THIS DRAWING NOTIFY THE PURCHASER PROMPTLY.

MAXIMUM ALLOWABLE TOLERANCES HAVE BEEN DETERMINED AND DEVIATIONS WILL BE CAUSE FOR REJECTION. REMOVE ALL BURRS AND SHARP EDGES

1057

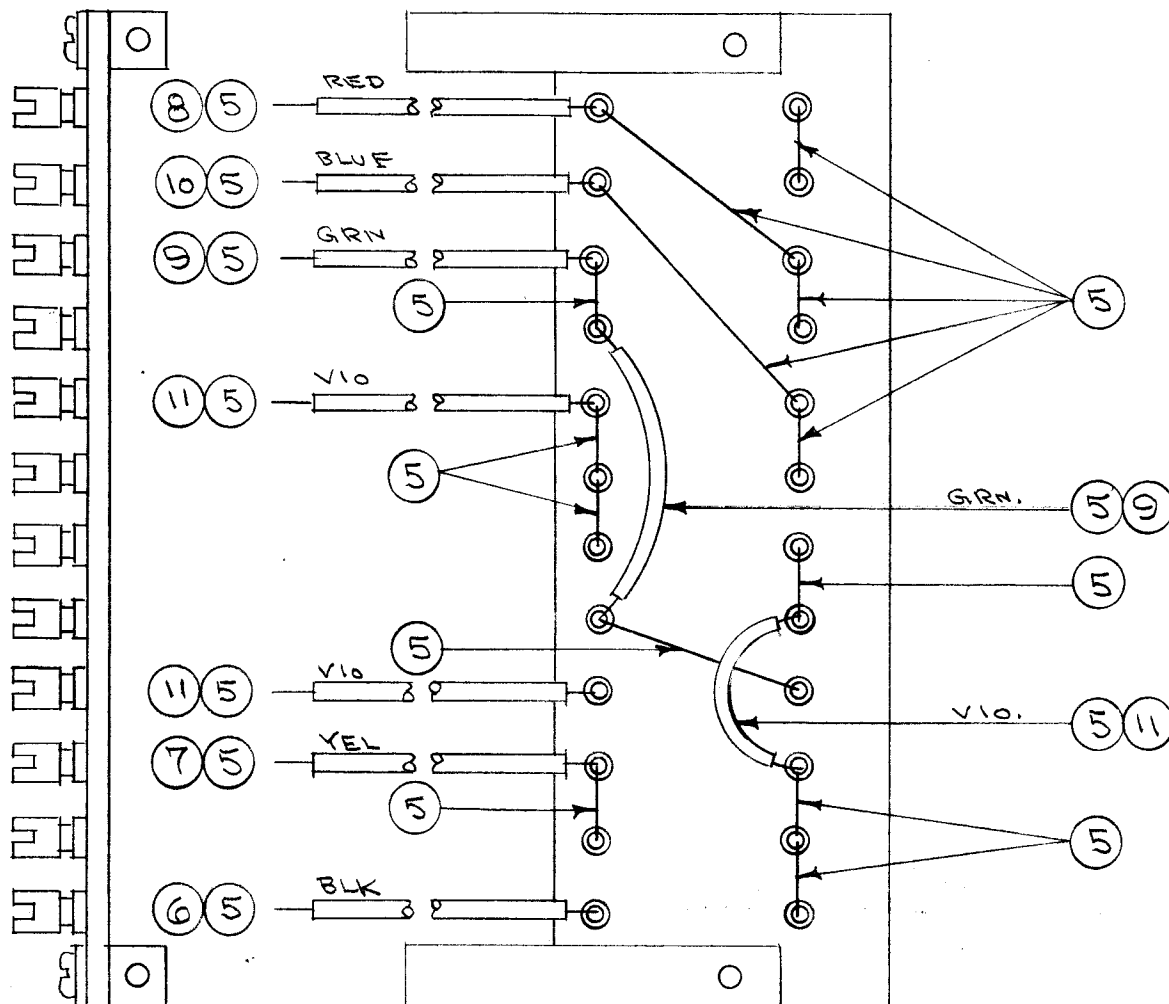
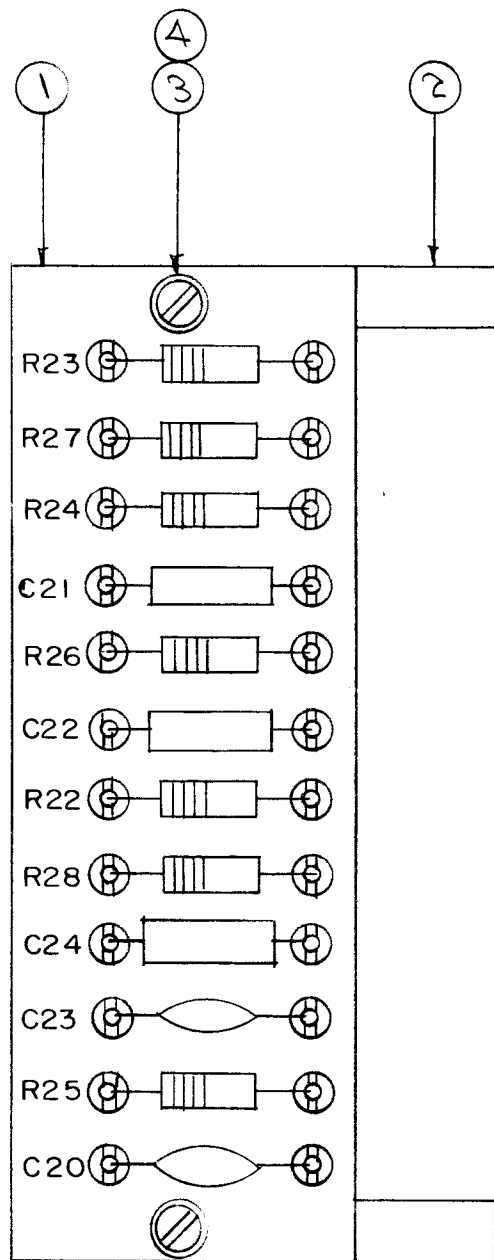

ALL LEADS 5" LONG. CUT SLEEVEING & LEADS TO FIT ON ASSEMBLY IN CHASSIS

NOTICE TO PERSONS RECEIVING THIS DRAWING

THE TECHNICAL MATERIEL CORPORATION claims proprietary right in the material disclosed hereon. This drawing is issued in confidence for engineering information only and may not be reproduced or used to manufacture anything shown hereon without permission from THE TECHNICAL MATERIEL CORPORATION to the user. This drawing is loaned for mutual assistance and is subject to recall at any time.

Property of:
THE TECHNICAL MATERIEL CORPORATION
MAMARONECK, NEW YORK

REQ.	ITEM	PART NO.	DESCRIPTION	SYMBOL
1	19	RC30GF 103K	RESISTOR, FIXED	R25
2	18	RC20GF 224K	" " "	R26 R24
2	17	RC30GF 223K	" " "	R27 R23
2	16	RC20GF 104K	" " "	R28 R22
1	15	CM20C471K	CAPACITOR, FIXED	C24
2	14	CC21SL470K	" " "	C22 C21
2	13	CC-100-16	" " "	C23 C20
X	12	BS-100	SOLDER, SOFT	
X	11	PX-104-9-.022	INSULATION, SLEEVEING VIO.	
X	10	PX-104-6-.022	" " " BLUE	
X	9	PX-104-4-.022	" " " GRN.	
X	8	PX-104-3-.022	" " " RED.	
X	7	PX-104-2-.022	" " " YEL	
X	6	PX-104-1-.022	" " " BLK.	
X	5	WL-100-7	WIRE, BUSS BAR 22 GA.	
2	4	SCBS0632BC6	SCREW, MACHINE	
2	3	LWE 06 MRC	WASHER, LOCK	
2	2	PM-350	SUPPORT	
1	1	A-1056	TERM. BD. SUB ASSY.	

ISSUE	ITEM	CHANGED FROM	DATE	CN. NO.	DRAFTS	CHECKER	ENG. APP.
TOLERANCES			SCALE:				
ALL OTHERS	DEC. DIM. ±	FRAC. DIM. ±	DRILL, PUNCH, COMMERCIAL STOCK SIZES AND MANUFACTURERS TOLERANCES ARE NOT INCLUDED.				

REQ. PER UNIT	MODEL	PROJECT NO.	ASSY. NO.	DATE
1	FSS			7-25-55
USED ON				

STOCK SIZE	MATERIAL	WEIGHT PER PC.	TYPE & TEMPER	HEAT TREAT. SPEC.	FINISH & SPEC. NO.
THE TECHNICAL MATERIEL CORP.					
MAMARONECK, NEW YORK					
TRIGGER & SCALE OF 2 TERM. BOARD ASSY. F.S.S.					
CDD 7-25-55		23			
DRAWN		ELEC. DES. APP.		MECH. DES. APP.	
JND		K2		A. J. J.	
CHECKED		FINAL APPROVAL			
		A-1057			