

IF IT IS FOUND DESIRABLE TO CHANGE ANY TOLERANCE OR OTHER DETAIL SPECIFIED ON THIS DRAWING NOTIFY THE PURCHASER PROMPTLY.

MAXIMUM ALLOWABLE TOLERANCES HAVE BEEN DETERMINED AND DEVIATIONS WILL BE CAUSE FOR REJECTION. REMOVE ALL BURRS AND SHARP EDGES

A-118 A

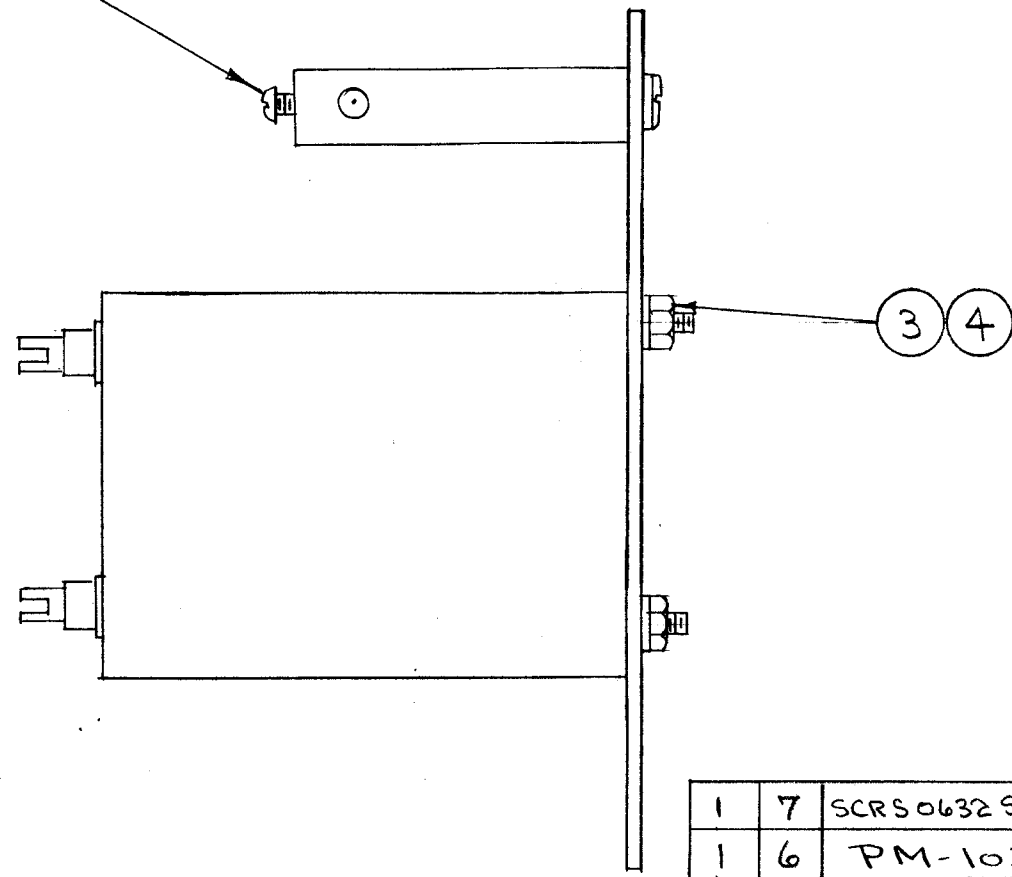
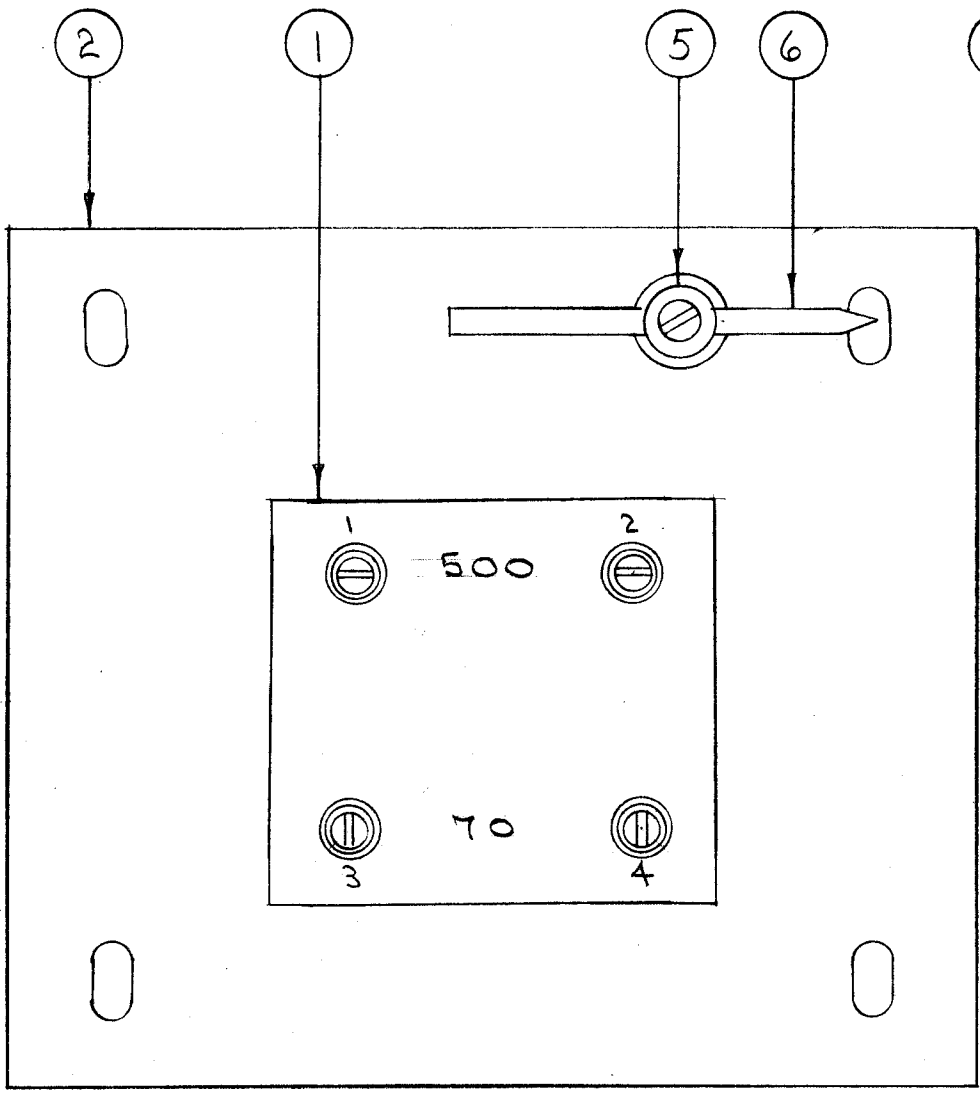

REQ.	ITEM	PART NO.	DESCRIPTION	SYMBOL
1	7	SCRS0632SN6	SCREW, MACHINE	
1	6	PM-103	SPARK ROD	
1	5	PM-102	POST	
4	4	LWE06MRC	WASHER, LOCK	
4	3	NTH0632BC8	NUT, HEX	
1	2	MS-109	MOUNTING PLATE	
1	1	TR-013	TRANSFORMER, R.F.	

REQ.	ITEM	PART NO.	DESCRIPTION	SYMBOL
STOCK SIZE			THE TECHNICAL MATERIEL CORP. MAMARONECK. NEW YORK	
TRANSFORMER AND PLATE				
SUB ASSEMBLY			C.D.D. 3-25-53	
TYPE & TEMPER			DRAWN	MECH. DES. APP.
HEAT TREAT. SPEC.			3-26-53	FINAL APPROVAL
FINISH & SPEC. NO.			A-118	

ISSUE	ITEM	CHANGED FROM	DATE	CN. NO.	DRAFTS	CHECKER	ENG. APP.
A	1	ITEM 3 WAS SCRS0632BEG	4/5/56	1	CDD	JAW	APP
-	-	REDRAWN - NO REVISION	3/26/53	-	CDD	JAW	PPT

TOLERANCES		SCALE:
ALL OTHERS	DEC. DIM. ± FRAC. DIM. ± ANGULAR DIM. ±	1

MODEL	PROJECT NO.	ASS'Y. NO.	DATE
BAC-3-S-20	108	A-108	7-24-52